

2016 CHOICE

COURSE SELECTION GUIDE



WEBSITE
WWW.TEKURA.SCHOOL.NZ

EMAIL
INFO@TEKURA.SCHOOL.NZ

FREEPHONE
0800 65 99 88

2016 CHOICE

COURSE SELECTION GUIDE

Welcome to Te Aho o Te Kura Pounamu

At the time of going to print the courses described in this guide are available for enrolment in 2016.

Refer to our website for the latest information on available courses, eligibility, standards and enrolment.

We may be required to withdraw or restrict enrolment to courses at any time. If you enrol in a course that is subsequently withdrawn or restricted in terms of enrolment, we will contact you to discuss other study options.

Information on NZQF standards are accurate at time of publication.

For more information, please contact us:

Website: www.tekura.school.nz

Email: info@tekura.school.nz

Freephone: 0800 65 99 88

We look forward to hearing from you.

Contents

Introduction		Home Economics	
Te Kupu Whakataki	5	Te Mātauranga Ohaoha Kāinga	65
Subjects at a glance		Horticulture	
Summary of subjects and levels of study	12	Te Mātauranga Ahuone	67
Accounting		Japanese	
Te Mātauranga Mahi Kaute	16	Te Reo Hapanihi	70
Agriculture		Latin	
Te Mātauranga Ahuwhenua	18	Te Reo Rōma Onamata	72
Art		Legal Studies	
Te Mātauranga Toi	20	Te Akoranga Taha Ture	73
Art History		Life Skills	
Te Toi Hitori	24	Ngā pūkenga whai oranga	75
Biology		Mathematics	
Te Mātauranga Koiora	25	Te Mātauranga Pāngarau	76
Business Studies		Media Studies	
Ngā Akoranga Umanga	27	Te Akoranga Pāpāho	81
Chemistry		Music	
Te Mātauranga Matū	29	Te Mātauranga Pūoru	83
Chinese		Pathways Education	
Te Reo Hainamana	31	Te Mātauranga Rapuara	85
Classical Studies		Performing Arts	
Te Akoranga Puāwaitanga	33	Ngā mahi ā te Rēhia	91
Commerce Studies		Physical Education	
Te Mātauranga Tauhokohoko	35	Mātauranga Hākinakina	92
Design and Visual Communication		Physics	
Ngā mahi hoahoa me te Whakawhitiwhiti ataata	37	Te Mātauranga Ahupūngao	94
Digital Technology		Science	
Te Hangarau Mamatai	40	Te Mātauranga Pūtaiao	96
Early Childhood		Social Studies	
Te Reanga Kōhungahunga	43	Te Akoranga Tikanga ā-iwi	102
Economics		Spanish	
Te Mātauranga Ōhanga	44	Te Reo Pāniora	103
English		Special Education Programme	
Te Reo Ingarihi	46	Te Akoranga Mothake	106
Enterprise Studies		Te Ara Hou Integrated Programme	
Ngā Akoranga Hinonga	51	Te Ara Hou	109
French		Technology	
Te Reo Wīwī	52	Te Mātauranga Hangarau	110
Gateway/STAR		Te Reo Māori	
Ngā Pokenga Mahi/STAR	54	Te Reo Māori	113
Geography		Tertiary Link/Huarahi Trades Academy	
Te Mātauranga Mātai Matawhenua	55	Te Wānanga Hononga/Huarahi	115
German		Years 1 to 6	
Te Reo Tiamana	57	Tau 1 ki te 6	116
Health Education		Index	
Mātauranga Hauora	60	Te Kupu Tohu	117
History			
Kōrero Nehe	62		

Introduction

Te Kupu Whakataki

This guide is designed to help students plan a programme of learning at Te Kura. All courses are based on the New Zealand Curriculum.

Learning with Te Kura, years 9–13

Students learn best when they work at their own pace, building and extending their existing knowledge and skills supported with regular feedback. Most courses are designed as one-year courses, but you may work faster or slower than this. Many courses offer a range of options and subject teachers will assist you with your choices. A number of courses at this level are delivered online through our Online Teaching and Learning Environment (OTLE). Access to a computer and the internet is essential for these courses. You will find details about the mode of delivery as part of each course's description in this book. See page 10 for information about the equipment you will need for working online. A valid email address must be supplied on enrolment.

Students enrolling in a one year NCEA course should aim to achieve 18–20 credits. This requires about 200 hours of student study time. It is important to take advice from your teacher, learning advisor and/or student support staff so that you choose a balanced programme of learning which matches your aspirations and abilities. A suitable learning programme may include courses across multiple curriculum or NCEA levels.

In addition to NCEA, subject specific national certificates are available for full-time students and young adults enrolled in three or more courses. Students work towards one of these certificates along with NCEA. Credits that count towards NCEA automatically count towards these certificates. NCEA may also be endorsed with one of the vocational pathways. See page 8 for more information on vocational pathways.

Online courses

Many courses are available online through our Online Teaching and Learning Environment as either interactive online modules or digital (PDF) versions of our printed booklets. OTLE is a web-based, password-protected online environment in which students can access a wide range of resources and activities. Online courses typically include a mix of activities such as quizzes and games, digital resources such as audio and video files, as well as practical activities students can work on away from the computer.

Teachers maintain an active presence in the OTLE and monitor students' work and any online discussions.

All courses at curriculum levels 3–5 and NCEA Level 1 are only available online. Students enrolling in online courses must have access to a suitable device and internet connectivity. Please check the description of each course for information about how the course is delivered before you enrol.

Selecting and planning your programme of learning

Student education plans

If you're a full-time student, you will work with your learning advisor to develop a personalised student education plan. Your learning advisor will ask you about your interests and goals and develop a plan with you to set out which subjects you'll study and when. The plan will align subjects and personal and career goals to ensure you keep options open for future study.

Authentic learning is a focus at Te Kura. Full-time students and young adults are encouraged to discuss authentic learning opportunities with their learning advisors. This may include work shadowing, informational interviews and STAR courses, Gateway placements, enrolment in a trades academy or an internship in your community. Te Kura has its own trades academy, Huarahi. If you are interested in being part of Huarahi, talk to your learning advisor or email huarahi@tekura.school.nz.

Full-time Year 9 and 10 students

Full-time Year 9 and 10 students are enrolled in Te Ara Hou, an integrated programme of learning that covers a number of core subjects with a choice of optional subjects, depending on learning needs, interests and your student education plan. Optional courses at this level and some Te Ara Hou modules are delivered online so you will require access to a computer and the internet. See page 9 for information about the equipment you will need for working online. Te Kura has an assistance programme available for full-time students who cannot access a suitable device and internet connectivity. There is more information about this on page 10.

Full-time Year 11 students

A full-time Year 11 programme is usually made up of English, mathematics, science and two or three other subjects. Your learning advisor will help you set goals and explore your interests to develop a personalised student education plan. This will determine the number of subjects you study and maintain your options for future study that links to career opportunities. NCEA Level 1 courses will be delivered online in 2016 through a mix of interactive modules and PDF (digital) booklets. Access to a computer and the internet is essential for students enrolling in any NCEA Level 1 courses. Te Kura has an assistance programme available for full-time students who cannot access a suitable device and internet connectivity. There is more information about this on page 10.

Full-time Year 12 and full-time Year 13 students

If you are a Year 12 or 13 student studying full-time with us, your programme will be based on your student education plan. Your learning advisor will help you set goals and explore your interests to determine your subjects and maintain your options for future study that links to career opportunities.

Fees

If you meet the Ministry of Education's criteria for enrolling with us, there are no school fees. For information on the Ministry's eligibility criteria for Te Kura, visit our website at www.tekura.school.nz.

Dual students

Students enrolled in New Zealand schools may be eligible for registration with us to study for courses not available at their own school.

Dual registrations must be made online by the host school through the Te Kura Enrolment System. Registrations are accepted through the year and open in November for the following school year. Before registering a student with Te Kura, schools must accept the terms of the Service Level Agreement for dual tuition, which sets out the responsibilities of both schools.

Schools are expected to ensure students are enrolled in the course at the most appropriate curriculum level. Some courses require prior study.

Courses at curriculum levels 3–8 (including NCEA) are only available to dual students in digital format, either as interactive online modules or as PDF files that can be downloaded from our OTLE. When enrolling in these courses, schools must ensure students have access to the required hardware, software and internet access. See page 9 for more information or visit our website at www.tekura.school.nz.

Young adults (16 to 19 years)

Students who have left school and are aged between 16 and 19 (and not turning 20) in the study year for which they are enrolling can enrol with Te Kura free of charge. Check the Te Kura website for more details on eligibility. We have a range of subjects available for enrolment by young adult students. Most enable students to earn credits towards national qualifications. You will have a student support advisor or learning advisor who will help you set goals and will personalise your programme of learning to support your achievement. Young adults enrolled in three or more courses which include a course at curriculum levels 3–5 and/or NCEA Level 1 may be eligible for assistance from Te Kura to access a suitable device or internet connectivity. See page 10 for more information. These students can also apply for Gateway, trades academy and STAR places. Talk to your learning advisor and see our website at www.tekura.school.nz for details.

Adult students

Adult students can enrol in one or more courses. Students aged 20 or over in the study year for which they are enrolling currently pay an administration fee of \$110 per course, but this fee may change.

The tuition administration fee will be waived for adult students where they commit to both receiving 000, Te Ara Hou or NCEA materials in a digital format and to returning all work electronically.

Fee-paying students

In some circumstances students who do not meet Ministry of Education eligibility criteria for a funded place may be able to enrol with Te Kura as a fee-paying student. Fees are on a per-course basis. Students already enrolled at another school must be registered and the fee paid by their home school. To find out more, visit our website at www.tekura.school.nz or contact us on 0800 65 99 88.

Studying for qualifications

Under the New Zealand Qualifications Framework (NZQF), it is possible to build a programme of learning so that credits attained can contribute to more than one qualification.

At Te Kura, we offer the NCEA certificates at Levels 1, 2 and 3, as well as other national certificates, so it is possible for students to work towards more than one qualification at the same time.

Detailed information about these qualifications can be found in the Student Guide to National Certificates on our website at www.tekura.school.nz/student-toolkit/earning-qualifications, or the New Zealand Qualifications Authority (NZQA) website at www.nzqa.govt.nz.

National Certificate of Educational Achievement

To gain the National Certificate of Educational Achievement (NCEA) Level 1, you must have 80 credits. These credits can be made up of unit standards and achievement standards at any level, including a literacy and numeracy requirement.

To gain NCEA Level 2, you must have 80 credits:

- 60 of these must be from standards at Level 2 or above
- 20 credits at Level 1 or above may have already been counted for Level 1 and still count towards a Level 2 certificate.

You must also meet the NCEA Level 1 literacy and numeracy requirements.

To gain NCEA Level 3, you must have 80 credits:

- 60 of these must be from standards at Level 3 or above
- 20 credits at Level 2 or above may have already been counted for Level 2 and still count towards a Level 3 certificate.

You must also meet the NCEA Level 1 literacy and numeracy requirements.

Literacy and numeracy requirements

Standards offered at Te Kura that count towards NCEA Level 1 literacy and numeracy requirements are identified in the course descriptions in this book.

- Literacy – either a minimum 10 credits through a package of three literacy unit standards or a minimum of 10 credits through specified achievement standards.
- Numeracy – either a minimum 10 credits through a package of three numeracy unit standards or a minimum of 10 credits through specified achievement standards.

For a full list of literacy and numeracy standards see www.nzqa.govt.nz/qualifications-standards/qualifications/ncea/subjects/literacy-and-numeracy/level-1-requirements/

Course endorsement

Students will gain course endorsement with merit if, in a calendar year, they gain 14 or more credits at merit and/or excellence in a course.

They will gain course endorsement with excellence if, in a calendar year, they gain 14 or more credits at excellence in a course.

These must include at least 3 credits from externally assessed standards and at least 3 credits from internally assessed standards in that course.

Some courses offer only externally assessed or internally assessed standards, and are therefore not eligible for endorsement.

Certificate endorsement

You can gain NCEA certificates endorsed with merit or excellence. A NCEA certificate endorsed with merit is awarded if you gain 50 credits at merit level (or a mix of merit and excellence). A NCEA certificate endorsed with excellence is awarded if you gain 50 credits at excellence level.

University Entrance

To be awarded University Entrance you must have:

- NCEA Level 3
- three subjects at Level 3 or above, made up of:
 - 14 credits each, in three approved subjects. (For a full list of approved subjects see www.nzqa.govt.nz/qualifications-standards/awards/university-entrance/approved-subjects/)
 - Literacy – 10 credits at Level 2 or above, made up of:
 - 5 credits in reading
 - 5 credits in writing
 - Numeracy – 10 credits at Level 1 or above made up of:
 - achievement standards – specified achievement standards available through a range of subjects, or
 - unit standards – package of three numeracy unit standards.

Standards available at Te Kura that count towards UE literacy and numeracy requirements are identified in the course descriptions in this book. (For a full list of UE literacy and numeracy standards see www.nzqa.govt.nz/qualifications-standards/awards/university-entrance/)

NZQA fees

Students studying courses that offer assessment against achievement and/or unit standards which count towards NCEA must pay a NZQA fee each year. The basic fee in 2015 was \$76.70, although students may be eligible for financial assistance that will reduce the fee. Payments made after 31 October must be paid direct to NZQA prior to 1 December to avoid an additional late fee of \$50.

Vocational pathways

NCEA Level 2 is the foundation for success in further education and the world of work. Vocational pathways provide ways to help students see how their learning and achievement will be valued in the workplace and the types of study options and job opportunities available.

Students can work towards achieving NCEA Level 2 endorsed in one of six vocational pathways:

- Primary Industries.
- Construction and Infrastructure.
- Manufacturing and Technology.
- Social and Community Services.
- Services Industries.
- Creative Industries.

To obtain a vocational pathways award, a student needs to gain NCEA Level 2 including:

- 60 Level 2 credits from **recommended** standards from a vocational pathways sector, including 20 credits from **sector-related** standards for that sector. To achieve these you will need to be part of our Gateway or trades academy, and participate in relevant STAR programmes.

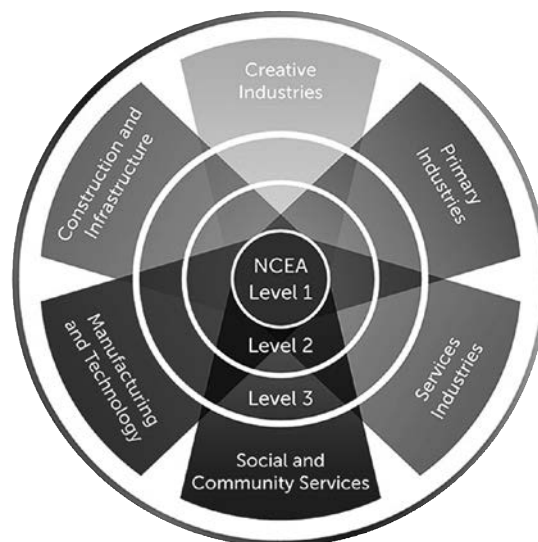

Vocational Pathways wheel diagram © New Zealand Ministry of Education. Used by permission.

Note 2016 is a transition year between old and new systems. In 2016, students will be able to gain a Vocational Pathways Award from EITHER the existing OR the refined pathways. This Te Kura document has the standards mapped against the 2016 standards only. For information about 2017 standards see <http://www.youthguarantee.net.nz/vocational-pathways/refined-levels-1-and-2>.

For more information, talk to your learning advisor or visit www.youthguarantee.net.nz.

National Certificates

Credits gained towards NCEA are automatically counted towards National Certificates by NZQA. Te Kura offers a wide range of National Certificates, some of which are completed through partnerships – such as Gateway, trades academies and work placements.

Huarahi Trades Academy

Huarahi Trades Academy offers a range of secondary-tertiary programmes around the country in trades and non-trades programmes. Te Kura has 18 partners and details are on our website. Te Kura works with polytechnics and Private Training Organisations to find a programme to suit each student wherever possible. Check our website for the most up-to-date list of options – www.tekura.school.nz/subjects-and-courses/huarahi-trades-academy.

Cross-curricular projects

Students may wish to learn through theme-based cross-curricular projects. The project can be in an area of interest, e.g. bee keeping, or it can be based around the student's daily life, e.g. a student who lives on a farm. The student works with their learning advisor to decide on the theme and scope of a project, and appropriate teaching and assessment. This is part of the authentic learning approach for gaining standards.

If you are interested in doing some or all of your learning by doing a project, contact your learning advisor once you are enrolled.

Equipment required for online learning

Every student enrolled in an online course needs a suitable device with internet connectivity.

A suitable device is one that enables the student to:

- access the internet and Te Kura's OTLE (via a web browser such as Google Chrome or Mozilla Firefox)
- create audio and video recordings, as well as still images
- create and edit documents, including spreadsheets and presentations (using PowerPoint or Prezi, for example).

A laptop or desktop computer, netbook, or tablet PC (also known as a Smart PC) with a hard disk drive of at least 80GB and a memory of more than 4GB are the best options as they offer a greater range of functionality than most standard tablets or iPads.

We recommend a data plan of 30GB. Households or learning centres with more than one student learning online may need more data than this, depending on the number and year level of the students. Dial-up internet is not suitable.

The OTLE itself provides a lot of the tools students will need to learn online, along with instructions on how to use them. Students learning online will also need an email address.

Here's a list of other equipment or software students may need.

Item	Essential	Desirable
Internet browser – Google Chrome, Mozilla Firefox or Safari	✓	
Webcam – built in or separate	✓	
Microphone (may be built into the device or separate)	Essential for courses such as languages and music which require audio recordings	✓
PDF editing software	Essential for most NCEA Level 1 courses and for dual-enrolled students	
Anti-virus software	✓	
Printer		✓
Scanner		✓

Digital camera – either a dedicated camera or built into a tablet or smartphone		✓
Headphones	Essential for languages courses	Desirable for other courses unless you have multiple students working in the same room
PDF editing software such as Adobe, PDF Escape	✓	
Word processing software such as Microsoft Office, Open Office, Google Drive or Office Works	✓	
An email account such as My Te Kura, Gmail, Yahoo, Hotmail etc.	✓	
A Gmail account for access to Google Docs	✓	
USB DVD drive		Desirable if your device does not have a built-in DVD drive

Access to a printer and scanner would be particularly useful for students enrolled in NCEA Level 1 courses, where students will be using a mix of interactive online modules and PDF files. We also recommend a surge protector, insurance and warranty cover for your device.

Device and connectivity assistance

Te Kura offers a laptop computer and internet subsidy of \$30 per month for eligible students enrolled in an online course in years 9 or 10 or at NCEA Level 1, for use while they are a student with Te Kura.

To be eligible, applicants must be the person who is primarily responsible for the education of the student, or be a young adult enrolled in three or more courses (at least one of which is defined as an online course for the purposes of this assistance programme¹). Applications must also meet the following criteria:

- the application is made on behalf of a full-time student enrolled in Te Ara Hou and/or an online course¹
- the applicant is a beneficiary or Community Services Card holder
- the applicant and student reside in New Zealand.

For the purposes of device and connectivity assistance, a young adult enrolled in three or more courses (at least one of which is defined as an online course for the purposes of this assistance programme) is considered to be a full-time student.

Additional connectivity assistance of \$30 per month is available for an eligible student enrolling through the following gateways:

- geographic inaccessibility
- geographic isolation
- itinerancy.

Applications for the 2016 school year open on 23 November 2015. A printed application form is available on request or you can apply over the telephone by calling Te Kura on 0800 65 99 88. The fastest way to apply is online through our website at www.tekura.school.nz – online applications that meet all the eligibility criteria will be automatically approved.

The devices we provide are refurbished (second-hand) laptop computers which have been loaded with the latest version of Microsoft Windows and some other software students may find useful, such as Adobe Reader. Students who withdraw from Te Kura must return the laptop. The internet subsidy is \$30 per month during the school year and is paid directly into the applicant's bank account. The subsidy will cease as soon as the student is no longer enrolled with Te Kura. Families of full-time students enrolled under the geographical isolation, geographical inaccessibility and itinerancy gateways can receive a top-up of their internet subsidy.

¹ An online course at curriculum levels 3–5 and/or a course at NCEA Level 1.

Programme planning

This document is organised by subject and level of study. These may be curriculum levels 1–8 or qualification levels NCEA 1–3. The diagram below illustrates how the curriculum levels work.

Years and Curriculum levels

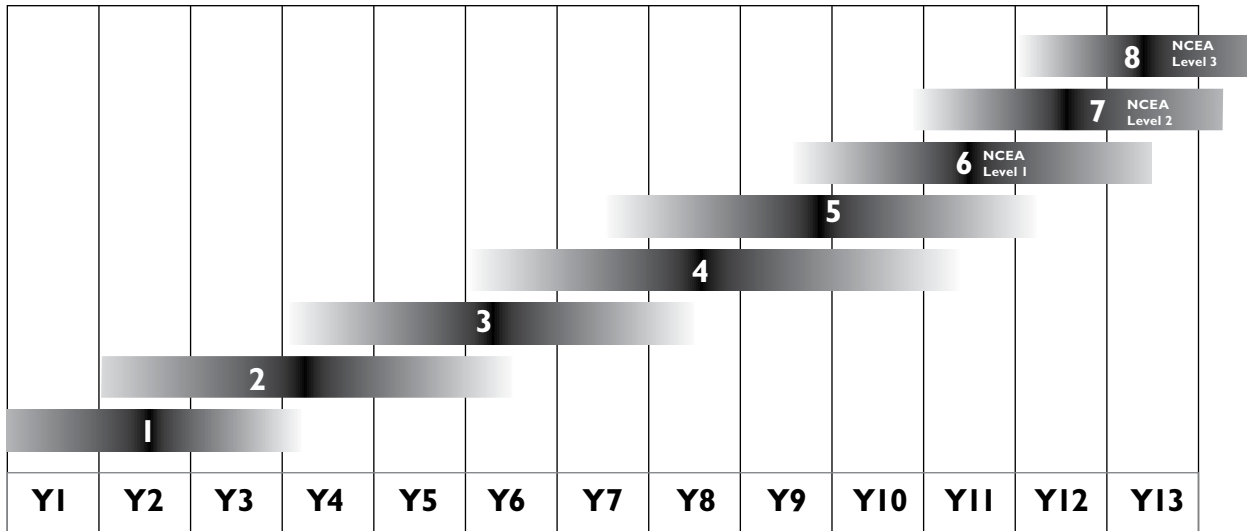

Diagram (adapted): Levels of Achievement by Years of Schooling, in the New Zealand Curriculum, first published by Learning Media Ltd on behalf of the Ministry of Education, Wellington, NZ. Copyright © Crown, Curriculum Doc, 2007. Used by permission.

Subjects at a glance

Summary of subjects and levels of study

Detailed information follows in this guide. Refer to www.tekura.school.nz/subjects-and-courses/what-you-can-study for the most up-to-date information.

Subject	Up to Curriculum Level 5	NCEA Level 1	NCEA Level 2	NCEA Level 3
Accounting		Accounting	Accounting	Accounting
Agriculture	Agriculture	Agriculture	Agriculture	Agriculture and Horticulture
Art (visual)	Visual Arts	Visual Arts	Painting	Painting
				Design
				Sculpture
				Printmaking
				Photography
Art History			Art History	Art History
Biology		Biology	Biology	Biology
Business Studies		Business Studies	Business Studies	
Chemistry		Chemistry	Chemistry	Chemistry
Chinese (Mandarin)	Chinese (beginners)	Chinese	Chinese	Chinese
Classical Studies			Classical Studies	Classical Studies
			Religious Studies	Religious Studies
Commerce Studies		Commerce Studies	Commerce Studies	
Digital Technology	Digital Technology	Digital Technology	Digital Technology	Digital Technology
Design and Visual Communication	Design and Visual Communication	Design and Visual Communication	Design and Visual Communication	Design and Visual Communication
Early Childhood	Early Childhood			
Economics		Economics	Economics	Economics
English	English	English	English	English
		Literacy		
Enterprise Studies	Enterprise Studies			
French	French (beginners)	French	French	French
Gateway		Gateway	Gateway	Gateway
Geography		Geography	Geography	Geography
German	German (beginners)	German	German	German
Health Education	Health Education	Health Education	Health Education	Health Education
History		History	History	History (England)
				History (New Zealand)
Home Economics	Home Economics	Home Economics	Home Economics	Home Economics
Horticulture	Horticulture	Horticulture	Horticulture	Agriculture and Horticulture

Subject	Up to Curriculum Level 5	NCEA Level 1	NCEA Level 2	NCEA Level 3
Japanese	Japanese (beginners)	Japanese	Japanese	Japanese
Latin	Latin (beginners)	Latin		
Legal Studies		Legal Studies	Legal Studies	Legal Studies
Life Skills	Life Skills			
Mathematics	Mathematics	Mathematics	Mathematics and Statistics	Calculus
		Numeracy for Everyday Life		Statistics
			Mathematics	
Media Studies		Media Studies	Media Studies	Media Studies
Music	Music	Music	Music	Music
Pathways Education		Pathways Education	Pathways Education	
		Pregnancy and Childcare	Pregnancy and Childcare	
Performing Arts		Dance	Dance	
Physics		Physics	Physics	Physics
Physical Education	Physical Education	Physical Education	Physical Education	Physical Education
Primary (Years 0–6)	Primary			
Science	Science	Science	Science (selection)	Science (selection)
		Everyday Science		
Social Studies	Social Studies			
Spanish	Primary Spanish	Spanish	Spanish	Spanish
	Spanish (beginners)			
Special Education Programme	Special Education			
Te Ara Hou (Years 7–10)	Te Ara Hou			
Technology	Technology	Technology	Technology	Technology
Te Reo Māori	Primary Te Reo Māori	Te Reo Māori	Te Reo Māori	Te Reo Māori
	Te Reo Māori (beginners)			

How to use this guide

The information in this guide is also available online. Refer to www.tekura.school.nz/subjects-and-courses/what-you-can-study for the most up-to-date information.

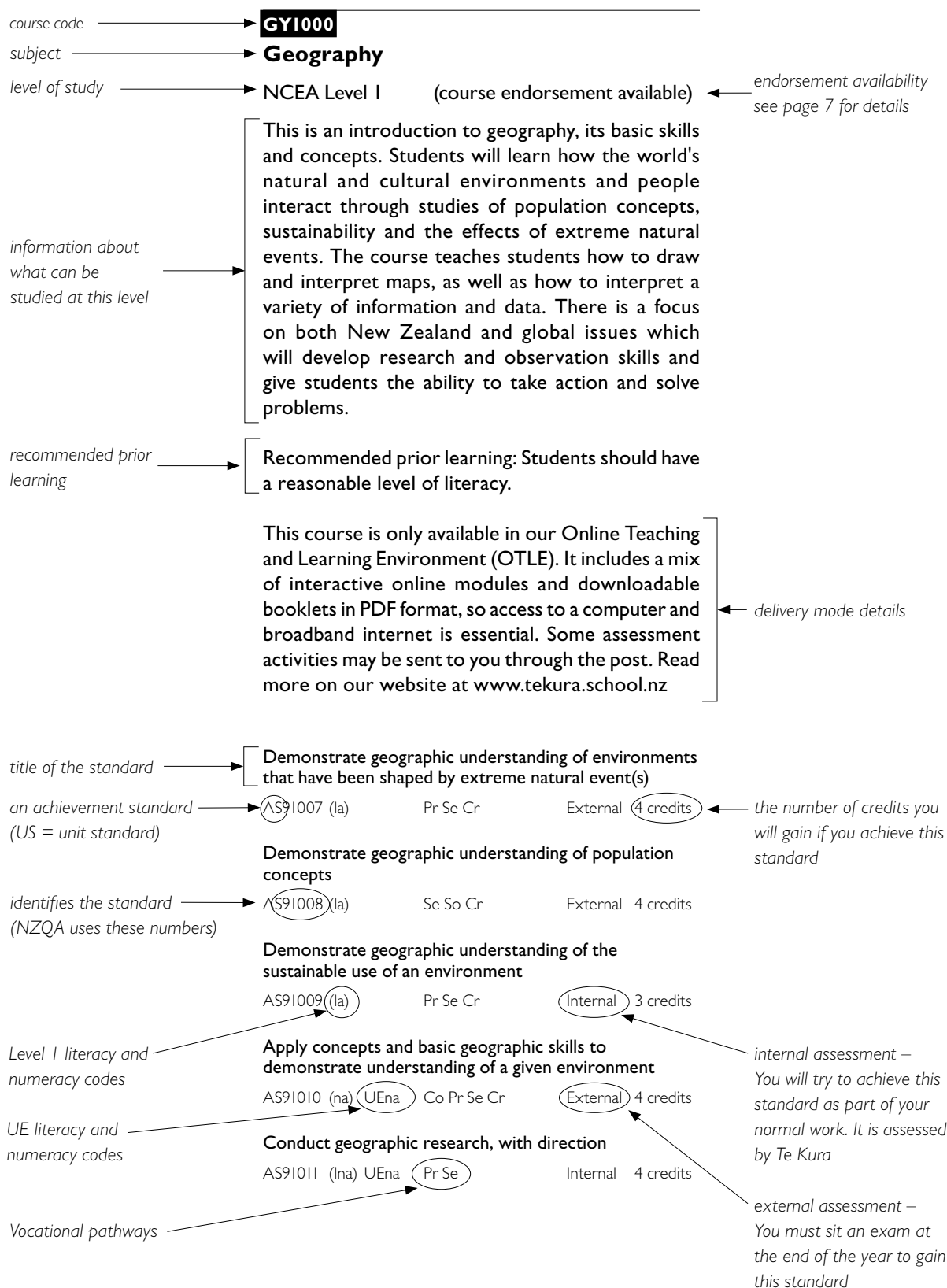

NCEA Level I Literacy and Numeracy requirements

For details of these requirements, please refer to the NZQA website –

www.nzqa.govt.nz/qualifications-standards/qualifications/ncea/subjects/literacy-and-numeracy/level-I-requirements/

Standards that count towards these requirements are identified as below

- (la) Literacy achievement standard
- (na) Numeracy achievement standard
- (lna) Literacy and numeracy achievement standard
- (nu) Numeracy unit standard
- (lu) Literacy unit standard

University Entrance literacy and numeracy requirements

For details of these requirements, please refer to the NZQA website –

www.nzqa.govt.nz/qualifications-standards/awards/university-entrance/

Standards that count towards these requirements are identified as below

- (UEna) UE numeracy achievement standard
- (UEnu) UE numeracy unit standard
- (UElwa) UE literacy writing achievement standard
- (UElra) UE literacy reading achievement standard
- (UElwra) UE literacy writing and reading achievement standard
- (UEnlra) UE numeracy and literacy reading achievement standard
- (UEnlwa) UE numeracy and literacy writing achievement standard

Vocational Pathways requirements

For details of these requirements, please refer to

<http://youthguarantee.net.nz/vocational-pathways/>

You can access this website directly or from your NZQA learner login.

Standards that count towards these requirements are identified as below

- Co Construction and Infrastructure recommended standard
- SCo Construction and Infrastructure sector-related standard
- Ma Manufacturing and technology recommended standard
- SMa Manufacturing and technology sector-related standard
- Pr Primary Industries recommended standard
- SPr Primary Industries sector-related standard
- Se Service Industries recommended standard
- SSe Service Industries sector-related standard
- So Social and Community Services recommended standard
- SSo Social and Community Services sector-related standard
- Cr Creative Industries recommended standard
- SCr Creative Industries sector-related standard

Accounting

Te Mātauranga Mahi Kaute

Accounting is fundamental not just for businesses but everyday life. It enhances students' financial literacy and gives them the tools to make real life financial decisions in a changing and uncertain world. Accounting includes the process of preparing and communicating financial information to a wide range of users. Further study can lead to diverse careers in accounting in many business environments worldwide. With a business or commerce degree, students can keep their options wide open.

AC1000

Accounting

NCEA Level 1 (course endorsement available)

This course gives students the tools to make real life financial decisions in a range of situations. Students are able to develop the knowledge and skills to manage the financial affairs of individuals, communities and businesses. Not only is there an emphasis on preparing financial information but also on communicating that information by way of reports. Accounting enhances financial literacy which is an essential lifelong skill.

Recommended prior learning: Students should have a reasonable level of literacy.

This course is only available in our Online Teaching and Learning Environment (OTLE). It includes a mix of interactive online modules and downloadable booklets in PDF format, so access to a computer and broadband internet is essential. Some assessment activities may be sent to you through the post. Read more on our website at www.tekura.school.nz

Demonstrate understanding of accounting concepts for small entities

AS90976 (la) Pr Se Cr External 3 credits

Process financial transactions for a small entity

AS90977 Se Cr Internal 5 credits

Prepare financial statements for sole proprietors

AS90978 Se Cr External 5 credits

Prepare financial information for a community organisation's annual general meeting

AS90979 (la) Se Cr Internal 4 credits

Interpret accounting information for sole proprietors

AS90980 (la) Pr Se Cr External 4 credits

Make a financial decision for an individual or group

AS90981 (la) Se Cr Internal 3 credits

Demonstrate understanding of cash management for a small entity

AS90982 (la) Se Cr Internal 4 credits

AC2000

Accounting

NCEA Level 2 (course endorsement available)

This course has a strong focus on accounting for sole traders and builds on the knowledge already gained in level 1. Students will gain further knowledge, skills and experience to manage a small business. Students will process and interpret financial transactions and then, more importantly, report on this financial information. A practical segment using a software computer programme, MYOB, is included. If you are interested in running your own business, this course takes you through the basics of managing inventory and accounts receivable processes.

Recommended prior learning: Students should have a reasonable level of literacy.

This course is booklet-based – you may download booklets in PDF format from our Online Teaching and Learning Environment (OTLE) or receive printed booklets through the post to complete and return for assessment.

If you are a secondary dual student, you must have access to a computer to download the PDF course booklets.

There are some optional supplementary online resources for this course which would be beneficial for your learning. Access to a computer and the internet is essential for these resources.

Demonstrate understanding of accounting concepts for an entity that operates accounting subsystems

AS91174 (la) Se Cr External 4 credits

Demonstrate understanding of accounting processing using accounting software

AS91175 (na) UEna Se Cr Internal 4 credits

Prepare financial information for an entity that operates accounting subsystems

AS91176 (na) UEna Cr External 5 credits

Interpret accounting information for entities that operate accounting subsystems

AS91177 (lna) UEna Cr External 4 credits

Demonstrate understanding of an accounts receivable subsystem for an entity
AS91179 (Ina) UEna Cr Internal 3 credits

Demonstrate understanding of an inventory subsystem for an entity
AS91386 (Ina) UEna Cr Internal 3 credits

Demonstrate understanding of a contemporary accounting issue for decision-making
AS91481 (Ia) Cr Internal 4 credits

AC3000

Accounting

NCEA Level 3 (course endorsement available)

Knowledge gained in the previous levels of study is developed within the context of companies and partnerships. Students will gain knowledge, skills and experience in using management for effective decision-making. Students will report, analyse and interpret information for partnerships, manufacturing businesses and companies. Accounting NCEA Level 3 and Scholarship prepares students for tertiary education. New Zealand Scholarship exams are designed to extend very high achieving level 3 students. Those who wish to enter for the NZ Scholarship exam in this subject must discuss this option with their Te Kura subject teacher.

Recommended prior learning: Students should have a reasonable level of accounting knowledge.

This course is booklet-based – you may download booklets in PDF format from our Online Teaching and Learning Environment (OTLE) or receive printed booklets through the post to complete and return for assessment.

If you are a secondary dual student, you must have access to a computer to download the PDF course booklets.

There are some optional supplementary online resources in OTLE for this course which would be beneficial for your learning. Access to a computer and the internet is essential for these resources.

Demonstrate understanding of accounting concepts for a New Zealand reporting entity
AS91404 (Ia) UEIra External 4 credits

Demonstrate understanding of accounting for partnerships
AS91405 (na) UEna Internal 4 credits

Demonstrate understanding of company financial statement preparation
AS91406 (na) UEna External 5 credits

Prepare a report for an external user that interprets the annual report of a New Zealand reporting entity
AS91407 (Ina) UEnlwra Internal 5 credits

Demonstrate understanding of management accounting to inform decision-making
AS91408 (Ina) UEna External 4 credits

Demonstrate understanding of a job cost subsystem for an entity
AS91409 (Ina) UEna Internal 4 credits

Agriculture

Te Mātauranga Ahuwhenua

Agriculture forms the backbone for many New Zealand communities and is the country's biggest export earner. If you are interested in farming animals or growing crops or have an interest in soil science then agriculture is the subject for you. Whether you are looking at farming as a career or have a general interest in agricultural science, studying agriculture will give you a greater understanding of how farming in New Zealand works and its relationship to the land and sustainable production practices. These courses also link into biology and horticulture.

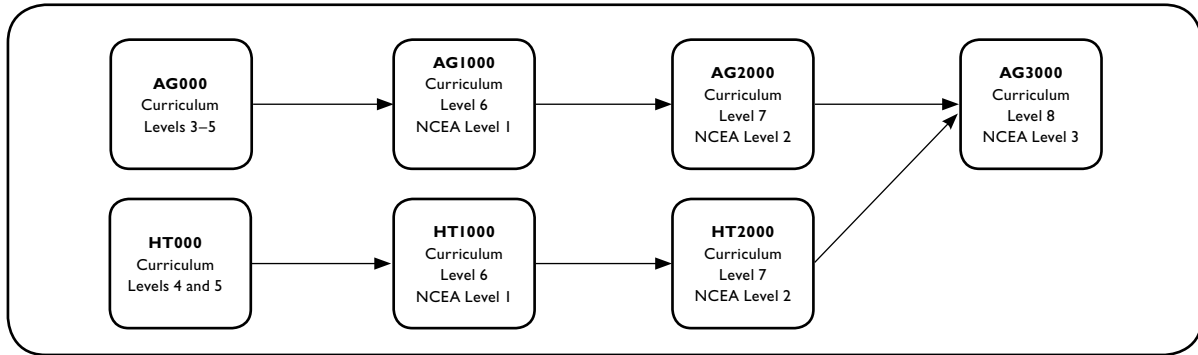

AG000

Introduction to Agriculture

Curriculum Levels 3–5

This is a general introduction to farming and includes some practical work. This course can be taken over two years. Topics include: sheep, dairy, pig farming, and forestry to name a few. The course can be taken as a progression into the AG1000 level 1 agriculture NCEA course.

Recommended prior learning: No prior learning needed.

This is an online course so access to a computer and broadband internet is essential. Some materials may be downloadable booklets in PDF format or sent to you through the post. Read more on our website at www.tekura.school.nz

AG1000

Agriculture

NCEA Level 1 (course endorsement available)

An introduction to agricultural science, this course covers not only the industry of agriculture and horticulture in New Zealand and farming production but environmental issues and animal diseases. The course starts by looking at animals and their care and pasture production. Students will develop the fundamental knowledge needed to manage livestock, pasture and soils.

Recommended prior learning: Students should have a reasonable level of literacy.

This course is only available in our Online Teaching and Learning Environment (OTLE). It includes a mix of interactive online modules and downloadable booklets in PDF format, so access to a computer and broadband internet is essential. Some assessment activities may be sent to you through the post. Read more on our website at www.tekura.school.nz

Demonstrate knowledge of pasture/crop management practices

AS90155 (la) Pr Internal 4 credits

Demonstrate knowledge of the impact on the environment of primary production management practices

AS90160 (la) Pr Internal 3 credits

Carry out a practical agricultural or horticultural investigation

AS90918 (na) UEna Pr Internal 4 credits

Demonstrate knowledge of soil management practices

AS90919 (la) Pr External 4 credits

Demonstrate knowledge of the geographic distribution of agricultural and horticultural primary production in New Zealand

AS90920 (la) Pr Internal 3 credits

Demonstrate knowledge of livestock management practices

AS90921 (la) Pr External 5 credits

AG2000

Agriculture

NCEA Level 2 (course endorsement available)

This agrifood production course covers animal, soil and pasture management practices, while considering the environmental issues that are affected by these practices. It looks at how the plant environment can be modified and how livestock can be managed to maximise production.

Recommended prior learning: Students should have a reasonable level of literacy.

This course is booklet-based – you may download booklets in PDF format from our Online Teaching and Learning Environment (OTLE) or receive printed booklets through the post to complete and return for assessment.

If you are a secondary dual student, you must have access to a computer to download the PDF course booklets.

You may also be sent audio CDs, DVDs, equipment and/or materials through the post.

There are some optional supplementary online resources for this course which would be beneficial for your learning. Access to a computer and the internet is essential for these resources.

Carry out an extended practical agricultural or horticultural investigation

AS91289 (na) UEna SPPr Internal 4 credits

Demonstrate understanding of techniques used to modify physical factors of the environment for NZ plant production

AS91290 (la) SPPr External 4 credits

Demonstrate understanding of livestock reproductive techniques in commercial production in New Zealand

AS91293 (la) SPPr Internal 4 credits

Demonstrate understanding of how NZ commercial management practices influence livestock growth and development

AS91294 (la) SPPr External 4 credits

Demonstrate understanding of interactions between livestock behaviour and NZ commercial management practices

AS91295 (la) SPPr Internal 4 credits

Report on the environmental impact of the production of a locally produced primary product

AS91298 (la) SPPr Internal 4 credits

AG3000

Agriculture and Horticulture

NCEA Level 3 (course endorsement available)

This combined agriculture and horticulture course will appeal to students with an interest in how primary products are produced and marketed to maximise profits. Based on the production process, students are given an insight into New Zealand's agricultural and horticultural exports, with a particular focus on lamb meat and apple crop production. The course links well with subjects such as biology, geography and economics.

Recommended prior learning: Students should have a reasonable level of literacy.

This course is booklet-based – you may download booklets in PDF format from our Online Teaching and Learning Environment (OTLE) or receive printed booklets through the post to complete and return for assessment.

If you are a secondary dual student, you must have access to a computer to download the PDF course booklets.

You may also be sent audio CDs, DVDs, equipment and/or materials through the post.

There are some optional supplementary online resources for this course which would be beneficial for your learning. Access to a computer and the internet is essential for these resources.

Carry out an investigation into an aspect of a New Zealand primary product or its production

AS91528 (lna) UEna Internal 4 credits

Research and report on the impact of factors on the profitability of a New Zealand primary product

AS91529 (lna) UEnlra Internal 6 credits

Demonstrate understanding of how market forces affect supply of and demand for New Zealand primary products

AS91530 (lna) UEnlwra External 5 credits

Demonstrate understanding of how the production process meets market requirements for a New Zealand primary product(s)

AS91531 (la) UElwra External 4 credits

Analyse a New Zealand primary production environmental issue

AS91532 (la) UElwra External 5 credits

Art

Te Mātauranga Toi

Visual arts is a creative subject that will provide students with an opportunity to develop art knowledge and skills. They will create artworks while learning about the work of various artists and the cultural and social contexts that their artworks reflect. Students can study visual arts to gain qualifications or just for general interest.

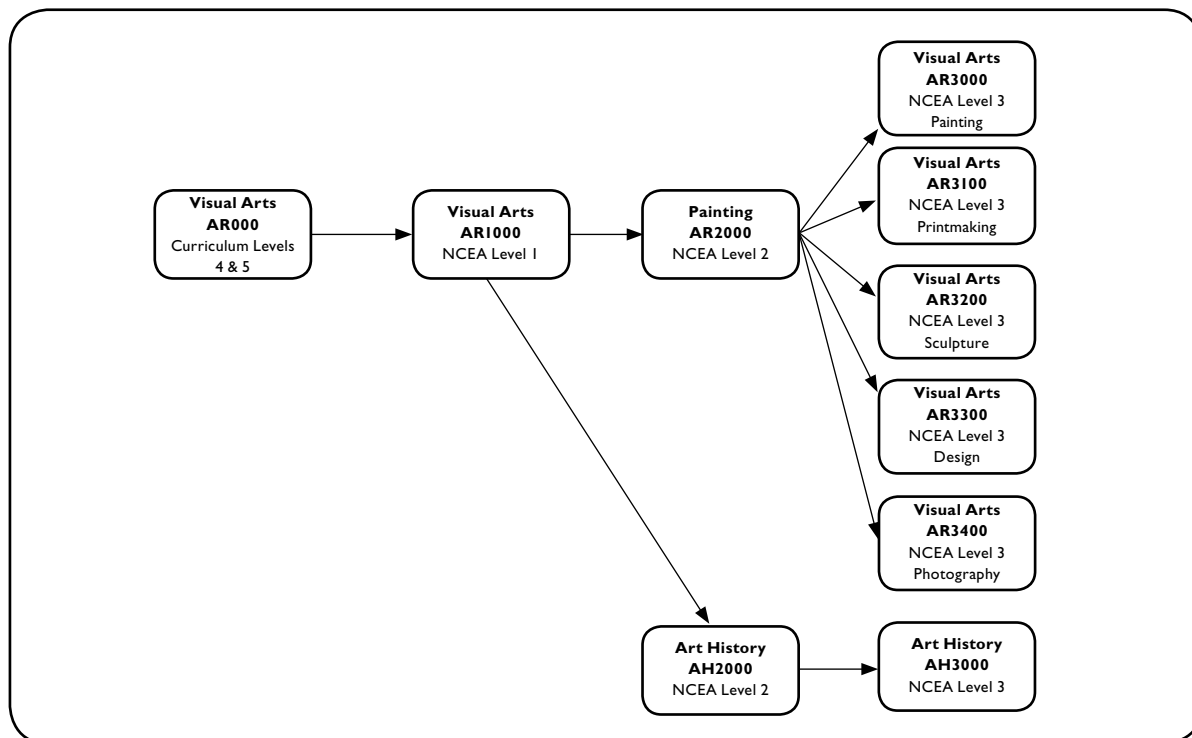

AR000

Visual Arts

Curriculum Levels 4 and 5

An introduction to drawing, painting, sculpture and design using a variety of techniques and media. An awareness of the process of developing artistic ideas from start to finish is introduced, and students can plan an appropriate programme to meet their needs and interests in art. Year 10 students can further develop skills and knowledge appropriate for moving forward to NCEA qualifications at Year 11.

Recommended prior learning: No prior learning needed.

This is an online course so access to a computer and broadband internet is essential. Read more on our website at www.tekura.school.nz

AR1000

Visual Arts

NCEA Level 1 (course endorsement available)

This is the first of the senior art courses for students who want qualifications in visual arts. It covers drawing, painting and printmaking. It includes: drawing using wet and dry media; lino printing; researching New Zealand artists from Māori, Polynesian and European; traditions and developing a body of work using a chosen theme/style for a folio. Students will have the opportunity to prepare for four internally assessed achievement standards and the externally assessed folio.

Recommended prior learning: Curriculum levels 4 and 5 Art or equivalent.

This course is only available in our Online Teaching and Learning Environment (OTLE). It includes a mix of interactive online modules and downloadable booklets in PDF format, so access to a computer and broadband internet is essential. Some assessment activities may be sent to you through the post. Read more on our website at www.tekura.school.nz

Demonstrate understanding of art works from a Māori and another cultural context using art terminology

AS90913 (la) Se Cr Internal 4 credits

Use drawing methods and skills for recording information using wet and dry media

AS90914 Cr Internal 4 credits

Use drawing conventions to develop work in more than one field of practice

AS90915 Cr Internal 6 credits

Produce a body of work informed by established practice, which develops ideas, using a range of media

AS90916 Cr External 12 credits

Produce a finished work that demonstrates skills appropriate to cultural conventions

AS90917 Se Cr Internal 4 credits

AR2000

Painting

NCEA Level 2 (course endorsement available)

In level 2 painting, students will explore a range of techniques and media. They will use a creative and a critical approach to develop original ideas and painting skills in a body of work. Subject matter will explore interior space or exterior landscape/urbanscape. Students are required to research contemporary New Zealand art practice.

Recommended prior learning: NCEA Level 1 Visual Art course or equivalent.

This is an online course, so access to a computer and broadband internet is essential. Read more on our website at www.tekura.school.nz

Demonstrate an understanding of methods and ideas from established practice appropriate to painting

AS91306 (la) Se SCr Internal 4 credits

Use drawing methods to apply knowledge of conventions appropriate to painting

AS91311 SCr Internal 4 credits

Develop ideas in a related series of drawings appropriate to established painting practice

AS91316 SCr Internal 4 credits

Produce a systematic body of work that shows understanding of art making conventions and ideas within painting

AS91321 SCr External 12 credits

Produce a resolved work that demonstrates control of skills appropriate to cultural conventions

AS91325 Se SCr Internal 4 credits

AR3000

Painting

NCEA Level 3 (course endorsement available)

In level 3 painting, students can study, develop and produce a body of work. They will learn to critically engage, evaluate and investigate artistic procedures and practices. Researching the work of contemporary artists will inform the development of their own ideas. Although the emphasis is on painting, student work can demonstrate influences from design, printmaking, sculpture and photography. New Zealand Scholarship exams are designed to extend very high achieving level 3 students. Those who wish to enter for the NZ Scholarship exam in this subject must discuss this option with their Te Kura subject teacher.

Recommended prior learning: NCEA Level 2 Visual Art course or equivalent.

This is an online course, so access to a computer and broadband internet is essential. Read more on our website at www.tekura.school.nz

Use drawing to demonstrate understanding of conventions appropriate to painting

AS91446 Internal 4 credits

Systematically clarify ideas using drawing informed by established painting practice

AS91451 Internal 4 credits

Produce a systematic body of work that integrates conventions and regenerates ideas within painting practice

AS91456 External 14 credits

AR3100

Printmaking

NCEA Level 3 (course endorsement available)

In level 3 printmaking, students can study, develop and produce a body of work. They will learn to critically engage, evaluate and investigate artistic procedures and practices. Researching the work of contemporary artists will inform the development of their own ideas. Although the emphasis is on printmaking, student work can demonstrate influences from design, painting, sculpture and photography.

New Zealand Scholarship exams are designed to extend very high achieving level 3 students. Those who wish to enter for the NZ Scholarship exam in this subject must discuss this option with their Te Kura subject teacher.

Recommended prior learning: NCEA Level 2 Visual Art course or equivalent.

This is an online course, so access to a computer and broadband internet is essential. Read more on our website at www.tekura.school.nz

Use drawing to demonstrate understanding of conventions appropriate to printmaking

AS91448 Internal 4 credits

Systematically clarify ideas using drawing informed by established printmaking practice

AS91453 Internal 4 credits

Produce a systematic body of work that integrates conventions and regenerates ideas within printmaking practice

AS91458 External 14 credits

AR3200

Sculpture

NCEA Level 3 (course endorsement available)

In level 3 sculpture, students can study, develop and produce a body of work. They will learn to critically engage, evaluate and investigate artistic procedures and practices. Researching the work of contemporary artists will inform the development of their own ideas. Although the emphasis is on sculpture, student work can demonstrate influences from design, printmaking, photography and painting. New Zealand Scholarship exams are designed to extend very high achieving level 3 students. Those who wish to enter for the NZ Scholarship exam in this subject must discuss this option with their Te Kura subject teacher.

Recommended prior learning: NCEA Level 2 Visual Art course or equivalent.

This is an online course, so access to a computer and broadband internet is essential. Read more on our website at www.tekura.school.nz

Use drawing to demonstrate understanding of conventions appropriate to sculpture

AS91449 Internal 4 credits

Systematically clarify ideas using drawing informed by established sculpture practice

AS91454 Internal 4 credits

Produce a systematic body of work that integrates conventions and regenerates ideas within sculpture practice

AS91459 External 14 credits

AR3300

Design

NCEA Level 3 (course endorsement available)

In level 3 design, students can study, develop and produce a body of work. They will learn to critically engage, evaluate and investigate artistic procedures and practices. Researching the work of contemporary artists and designers will inform the development of their own ideas. Although the emphasis is on design, student work can demonstrate influences from printmaking, photography, painting and sculpture. New Zealand Scholarship exams are designed to extend very high achieving level 3 students. Those who wish to enter for the NZ Scholarship exam in this subject must discuss this option with their Te Kura subject teacher.

Recommended prior learning: NCEA Level 2 Design or equivalent study and experience of digital media applications (Photoshop, InDesign). All enquiries regarding equivalency should be directed to the senior teacher of the subject prior to enrolment and registration.

This is an online course, so access to a computer and broadband internet is essential. Read more on our website at www.tekura.school.nz

Use drawing to demonstrate understanding of conventions appropriate to design

AS91445 Internal 4 credits

Systematically clarify ideas using drawing informed by established design practice

AS91450 Internal 4 credits

Produce a systematic body of work that integrates conventions and regenerates ideas within design practice

AS91455 External 14 credits

AR3400**Photography**

NCEA Level 3 (course endorsement available)

In level 3 photography, students can study, develop and produce a body of work. They will learn to critically engage, evaluate and investigate artistic procedures and practices. Researching the work of contemporary artists and designers will inform the development of their own ideas. Although the emphasis is on photography, student work can demonstrate influences from printmaking, design, painting and sculpture. New Zealand Scholarship exams are designed to extend very high achieving level 3 students. Those who wish to enter for the NZ Scholarship exam in this subject must discuss this option with their Te Kura subject teacher.

Recommended prior learning: NCEA Level 2 Photography or equivalent study and experience of digital media applications (Photoshop, InDesign). All enquiries regarding equivalency should be directed to the senior teacher of the subject prior to enrolment and registration.

This is an online course, so access to a computer and broadband internet is essential. Read more on our website at www.tekura.school.nz

Use drawing to demonstrate understanding of conventions appropriate to photography

AS91447 Internal 4 credits

Systematically clarify ideas using drawing informed by established photography practice

AS91452 Internal 4 credits

Produce a systematic body of work that integrates conventions and regenerates ideas within photography practice

AS91457 External 14 credits

Art History

Te Toi Hitori

Art History is recommended for students who have an interest in art and how and why it has been produced. It involves the observation, analysis and interpretation of works of art and places them within their cultural and historical context. Through this subject students will develop the analytical, critical and research skills needed to gain a greater understanding of artistic ideas and concepts. It is not necessary to have any practical skills in art.

AH2000

Art History

NCEA Level 2 (course endorsement available)

Towards modernism (nineteenth century French art) and art in Aotearoa are used as starting points for students to develop the art historical skills of observation, analysis and understanding of content and context.

Recommended prior learning: A reasonable level of literacy is required.

This is an online course, so access to a computer and broadband internet is essential. Read more on our website at www.tekura.school.nz

Examine the effects of formal elements of art works

AS91180 (la) UElwa SCr External 4 credits

Examine the meanings conveyed by art works

AS91181 (la) UElwa Se SCr External 4 credits

Examine the influence of context(s) on art works

AS91182 (la) UElwa SCr External 4 credits

Examine how media are used to create effects in art works

AS91183 (la) Se SCr Internal 4 credits

Communicate understanding of an art history topic

AS91184 (la) UElra SCr Internal 4 credits

Communicate a considered personal response to art works

AS91185 (la) SCr Internal 4 credits

Demonstrate understanding of art works in relation to their physical environments

AS91186 (la) Se SCr Internal 4 credits

AH3000

Art History

NCEA Level 3 (course endorsement available)

The focus of this course is Renaissance Art, a period that helped shape the history of art. At the heart of this course is the ability to analyse and interpret art within a cultural and historical context. The option offered is Late Renaissance to Mannerism. This course is recommended to students with an interest in the arts, English, history or classical studies. It is also useful if considering further tertiary study in any of these areas. It is not necessary to have studied art history at level 2. New Zealand Scholarship exams are designed to extend very high achieving level 3 students. Those who wish to enter for the NZ Scholarship exam in this subject must discuss this option with their Te Kura subject teacher.

Recommended prior learning: A good level of literacy is required.

This is an online course, so access to a computer and broadband internet is essential. Read more on our website at www.tekura.school.nz

Demonstrate understanding of style in art works

AS91482 (la) UElwra External 4 credits

Examine how meanings are communicated through art works

AS91483 (la) UElwra External 4 credits

Examine the relationship(s) between art and context

AS91484 (la) UElwra External 4 credits

Examine the impact of media and processes on art works

AS91485 (la) UElra Internal 4 credits

Construct an argument based on interpretation of research in art history

AS91486 (la) UElra Internal 4 credits

Examine the relationship(s) between a theory and art works

AS91488 (la) UElra Internal 4 credits

Analyse texts about art

AS91489 (la) UElra Internal 4 credits

Biology

Te Mātauranga Koiora

Biology is at the centre of all life and through this subject students will explore the living world, its ecology, plant and animal life processes, evolution, and relationships between biology and technology. Along with gaining an understanding of themselves, the world, and how organisms survive and live together, students will develop essential scientific knowledge, methods and techniques. From here, students will be able to analyse scientific information effectively and discuss the wide range of implications science has on our world, including medical and environmental issues. It is a broad interest subject and important for many careers, from health professional through to forestry and zoology.

BY1000

Biology

NCEA Level 1 (course endorsement available)

This course provides an introduction to the living world, its ecology, and human organ systems. The same standards are also available in SCI1000 which offers a wider choice of standards. Students wishing to continue with biological studies at level 2 and beyond are advised to enrol for SCI1000, in addition to BY1000, and to prepare for at least one SCI1000 external (AS90948) and one externally assessed BY1000 standard (AS90927, AS90928 or AS90929).

Recommended prior learning: Students should have a reasonable level of literacy.

This course is only available in our Online Teaching and Learning Environment (OTLE). It includes a mix of interactive online modules and downloadable booklets in PDF format, so access to a computer and broadband internet is essential. Some assessment activities may be sent to you through the post. Read more on our website at www.tekura.school.nz

Carry out a practical investigation in a biological context, with direction

AS90925 (na) UEna Ma Pr Se So Internal 4 credits

Report on a biological issue

AS90926 (la) Pr Internal 3 credits

Demonstrate understanding of biological ideas relating to micro-organisms

AS90927 (la) Ma Pr So External 4 credits

Demonstrate understanding of biological ideas relating to the life cycle of flowering plants

AS90928 (la) Pr External 4 credits

Demonstrate understanding of biological ideas relating to a mammal(s) as a consumer(s)

AS90929 (la) Pr Se So External 3 credits

Demonstrate understanding of biological ideas relating to genetic variation

AS90948 (la) Ma Pr So Cr External 4 credits

Investigate life processes and environmental factors that affect them

AS90949 Pr Se So Cr Internal 4 credits

Investigate biological ideas relating to interactions between humans and micro-organisms

AS90950 Co Ma Pr Se So Cr Internal 4 credits

Investigate the biological impact of an event on a New Zealand ecosystem

AS90951 Pr Se Cr Internal 4 credits

BY2000

Biology

NCEA Level 2 (course endorsement available)

This NCEA level 2 course offers the student the opportunity to explore topics such as ecology, genetics and gene expression. Alongside these topics, students will study cell structure and processes and will gain skills to analyse the increasing complexity of biological information that is presented to the public. They will also be able to carry out a practical investigation. Not only is this course highly relevant, it is essential preparation for both the level 3 Biology course and for students intending to enter tertiary studies in nursing, medicine, veterinary and similar fields. To be able to successfully start level 3 Biology, students should have studied AS91156, AS91159 and, if they want to carry out the level 3 Biology practical investigation, they will need to complete AS91153.

Recommended prior learning: Students should have a reasonable level of literacy and have successfully studied at least AS90948 and AS90949 from level 1 Science/Biology.

This course is booklet-based – you may download booklets in PDF format from our Online Teaching and Learning Environment (OTLE) or receive printed booklets through the post to complete and return for assessment.

If you are a secondary dual student, you must have access to a computer to download the PDF course booklets.

You may also be sent audio CDs, DVDs, equipment and/or materials through the post.

There are some optional supplementary online resources for this course which would be beneficial for your learning. Access to a computer and the internet is essential for these resources.

Carry out a practical investigation in a biology context, with supervision

AS91153 (na) UEna Ma Pr Se So Internal 4 credits

Analyse the biological validity of information presented to the public

AS91154 (la) Pr So Internal 3 credits

Demonstrate understanding of adaptation of plants or animals to their way of life

AS91155 (la) Pr Se So Internal 3 credits

Demonstrate understanding of life processes at the cellular level

AS91156 (la) Pr So External 4 credits

Demonstrate understanding of genetic variation and change

AS91157 (la) Pr So External 4 credits

Investigate a pattern in an ecological community, with supervision

AS91158 (la) Pr Internal 4 credits

Demonstrate understanding of gene expression

AS91159 (la) Pr So External 4 credits

BY3000

Biology

NCEA Level 3 (course endorsement available)

This course follows on from level 2 Biology. In this course students will be able to study plant responses and animal behaviour, biotechnology, evolution, and speciation. Students will also have the opportunity to further develop their investigative and research skills. As well as being highly relevant, this course is useful, and often essential, for students intending to enter tertiary studies in nursing, medicine, veterinary science and/or similar fields. University Entrance requires students to have 14 level 3 Biology credits. This means they should sit at least one, preferably two, externally assessed standards. If students intend to complete AS91601 they should do this in term one or two of the school year.

Recommended prior learning: Students should have a good level of literacy. They also need to have studied cell structure and processes (AS91156), and gene expression (AS91159) from level 2 Biology before heading into this course. Students intending to complete the practical investigation (AS91601) are required to have studied the level 2 practical investigation (AS91153).

This course is booklet-based – you may download booklets in PDF format from our Online Teaching and Learning Environment (OTLE) or receive printed booklets through the post to complete and return for assessment.

If you are a secondary dual student, you must have access to a computer to download the PDF course booklets.

You may also be sent audio CDs, DVDs, equipment and/or materials through the post.

There are some optional supplementary online resources for this course which would be beneficial for your learning. Access to a computer and the internet is essential for these resources.

Carry out a practical investigation in a biological context, with guidance

AS91601 (Ina) UEna Internal 4 credits

Integrate biological knowledge to develop an informed response to a socio-scientific issue

AS91602 (la) UElwra Internal 3 credits

Demonstrate understanding of the responses of plants and animals to their external environment

AS91603 (la) UElwra External 5 credits

Demonstrate understanding of how an animal maintains a stable internal environment

AS91604 (la) UElra Internal 3 credits

Demonstrate understanding of evolutionary processes leading to speciation

AS91605 (la) UElwra External 4 credits

Demonstrate understanding of trends in human evolution

AS91606 (la) UElwra External 4 credits

Demonstrate understanding of human manipulations of genetic transfer and its biological implications

AS91607 (la) UElra Internal 3 credits

Business Studies

Ngā Akoranga Umanga

The study of business is about how individuals and groups of people organise, plan and act to produce goods and services to satisfy customers. In a rapidly changing world, it is important that citizens are able to make informed and rational decisions about business matters. Business Studies covers five key themes that encompass business knowledge, content and concepts – business formation, functions of business, people in business, business management and the business environment. The knowledge and skills gained in Business Studies and exposure to enterprise culture can help shape ‘creative, energetic and enterprising’ people who will contribute to New Zealand’s economic future. In Business Studies, students develop their understanding of business theory and practices in a range of relevant contexts.

BS1000

Business Studies

NCEA Level 1 (course endorsement available)

In this course students will explore the five key themes (business formation, functions of business, people in business, business management and the business environment) within the context of a small-to-medium business, of local or community significance (or focus), and connected to their life; for example, a local farm, tourist operator, retail outlet, franchise, or early childcare centre. Students will study the internal features of businesses, external factors that influence their success, and operational business problems and provide causes, impacts, possible solutions and recommendations to address these. The marketing mix and the human resources process are also studied in this course. Students will gain knowledge of enterprising behaviour, innovation and entrepreneurship in business contexts.

Recommended prior learning: Students should have a reasonable level of literacy.

This course is only available in our Online Teaching and Learning Environment (OTLE). It includes a mix of interactive online modules and downloadable booklets in PDF format, so access to a computer and broadband internet is essential. Some assessment activities may be sent to you through the post. Read more on our website at www.tekura.school.nz

Demonstrate and apply knowledge of office equipment and administration processes

US121 SSe Cr Internal 5 credits

Demonstrate knowledge of enterprising behaviour, innovation, and entrepreneurship in business contexts

US22847 Cr Internal 2 credits

Demonstrate an understanding of internal features of a small business

AS90837 (1a) Pr Se Cr External 4 credits

Demonstrate an understanding of external factors influencing a small business

AS90838 (1a) Pr Se Cr External 4 credits

Apply business knowledge to an operational problem(s) in a given small business context

AS90839 (1a) Pr Cr External 4 credits

Apply the marketing mix to a new or existing product

AS90840 (1a) Pr Se Cr Internal 3 credits

Investigate aspects of human resource processes in a business

AS90841 (1a) Pr Cr Internal 3 credits

BS2000

Business Studies

NCEA Level 2 (course endorsement available)

In this course students will explore the five key themes (business formation, functions of business, people in business, business management and the business environment) within the context of medium and large business, of regional or national significance, and connected to their life; for example, a listed company, a retail company with multiple outlets, a school, local government, a large corporate, or a bank. Students will study the internal operations of a business, how large businesses respond to external factors, critical business problems, and apply business knowledge to provide possible solutions and recommendations to address issues. Students will have the opportunity to conduct market research and identify motivation practices and apply their knowledge of motivation theory in a business.

Recommended prior learning: Students should have a reasonable level of literacy.

This course is booklet-based – you may download booklets in PDF format from our Online Teaching and Learning Environment (OTLE) or receive printed booklets through the post to complete and return for assessment.

If you are a secondary dual student, you must have access to a computer to download the PDF course booklets.

There are some optional supplementary online resources for this course which would be beneficial for your learning. Access to a computer and the internet is essential for these resources.

Demonstrate and apply knowledge of office equipment and administration processes

USI21 SSe Cr Internal 5 credits

Demonstrate understanding of the internal operations of a large business

AS90843 (la) Pr Se Cr External 4 credits

Demonstrate understanding of how a large business responds to external factors

AS90844 (la) Pr Se Cr External 4 credits

Apply business knowledge to a critical problem(s) in a given large business context

AS90845 (la) Pr Cr External 4 credits

Conduct market research for a new or existing product

AS90846 (lna) UEna Pr Se Cr Internal 3 credits

Investigate the application of motivation theory in a business

AS90847 (la) Se Cr Internal 3 credits

Chemistry

Te Māturanga Matū

People have always been fascinated by the world around us and chemistry is the study of the very substances that make up the universe. From the time people worked out how to create fire, it has been chemistry at the forefront of exciting discoveries such as the structure of DNA and the use of semiconductors in electronics. Chemistry looks at the behaviour of substances, the changes they undergo to create new ones and the reactions between them. Yet it is more than what happens at micro level, it is about what it is that makes us, our materials and everything around us. Alongside this, you will learn essential skills and knowledge needed to analyse scientific information, conduct experiments and research. Chemistry is essential for a wide range of careers including medicine, pharmacy, engineering and environmental science, through to wine making and food technology.

CHI000

Chemistry

NCEA Level 1 (course endorsement available)

This course provides an introduction to the basics of chemistry. Students should enrol for this course if they wish to focus on studying the material world and intend to sit at least one externally assessed examination paper. Students wishing to continue with level 2 Chemistry should complete at least the standard on acids and bases (AS90944). Students are expected to complete five of the standards listed below.

Recommended prior learning: Students should have a reasonable level of literacy.

This course is only available in our Online Teaching and Learning Environment (OTLE). It includes a mix of interactive online modules and downloadable booklets in PDF format, so access to a computer and broadband internet is essential. Some assessment activities may be sent to you through the post. Read more on our website at www.tekura.school.nz

Carry out a practical chemistry investigation, with direction

AS90930 (na) UEna Co Ma Pr Se Cr Internal 4 credits

Demonstrate understanding of the chemistry in a technological application

AS90931 (la) Co Ma Pr Se Cr Internal 2 credits

Demonstrate understanding of aspects of carbon chemistry

AS90932 Co Ma Pr Cr External 4 credits

Demonstrate understanding of aspects of selected elements

AS90933 Co Ma Pr Cr External 4 credits

Demonstrate understanding of aspects of chemical reactions

AS90934 Co Pr Cr External 4 credits

Demonstrate understanding of aspects of acids and bases

AS90944 Co Ma Pr Cr External 4 credits

Investigate implications of the use of carbon compounds as fuels

AS90945 Co Ma Pr Se So Cr Internal 4 credits

Investigate selected chemical reactions

AS90947 Co Ma Pr So Cr Internal 4 credits

CH2000

Chemistry

NCEA Level 2 (course endorsement available)

This course further develops some of the chemistry topics introduced in level 1 Science, and investigates general scientific nature and problems, oxidation and reduction, and the various reactions chemical substances undergo. The use of formulae and equations and the application of mathematics to these are a very important part of the course. Practical work is part of this course, much of which can be done at home. Note: AS91161 requires access to a school or industrial laboratory. AS91163 requires a good understanding of level 2 Chemistry and so is normally attempted last.

Recommended prior learning: AS90944 or equivalent.

This course is booklet-based – you may download booklets in PDF format from our Online Teaching and Learning Environment (OTLE) or receive printed booklets through the post to complete and return for assessment.

If you are a secondary dual student, you must have access to a computer to download the PDF course booklets.

You may also be sent audio CDs, DVDs, equipment and/or materials through the post.

There are some optional supplementary online resources for this course which would be beneficial

for your learning. Access to a computer and the internet is essential for these resources.

Carry out quantitative analysis

AS91161 (na) UEna Co Ma Pr So Cr Internal 4 credits

Demonstrate understanding of the chemistry used in the development of a current technology

AS91163 (la) Co Ma Pr Se So Cr Internal 3 credits

Demonstrate understanding of bonding, structure, properties and energy changes

AS91164 (la) Co Ma Pr So Cr External 5 credits

Demonstrate understanding of the properties of selected organic compounds

AS91165 (la) Co Ma Pr Se So Cr External 4 credits

Demonstrate understanding of chemical reactivity

AS91166 (la) Co Ma Pr Se So Cr External 4 credits

Demonstrate understanding of oxidation-reduction

AS91167 Co Ma Pr So Cr Internal 3 credits

CH3000

Chemistry

NCEA Level 3 (course endorsement available)

The course investigates further what it is that helps create our world, and takes the concepts discussed in level 2 to a more advanced level. There is a focus on the role of energy and using particles at the microscopic level to explain the properties observed at the macroscopic level.

Topics introduced include electronic structures and spontaneity of reactions including electrochemical processes. Spectroscopic analysis of organic compounds is also investigated. Since quantitative analysis is involved with chemistry, confidence in general mathematics, simple algebra and graphs are useful and the course is aimed at students going on to tertiary studies in chemistry.

Note: AS91389 requires a good understanding of level 3 Chemistry and so should be completed near the end of the course.

Recommended prior learning: Five standards completed at NCEA Level 2 Chemistry or equivalent.

This course is booklet-based – you may download booklets in PDF format from our Online Teaching and Learning Environment (OTLE) or receive

printed booklets through the post to complete and return for assessment.

If you are a secondary dual student, you must have access to a computer to download the PDF course booklets.

You may also be sent audio CDs, DVDs, equipment and/or materials through the post.

There are some optional supplementary online resources for this course which would be beneficial for your learning. Access to a computer and the internet is essential for these resources.

Analyse oxidation-reduction reactions

US6345 Internal 4 credits

Characterise the composition of acid and base solutions

US8949 Internal 4 credits

Demonstrate understanding of spectroscopic data in chemistry

AS91388 Internal 3 credits

Demonstrate understanding of chemical processes in the world around us

AS91389 (la) UEIwra Internal 3 credits

Demonstrate understanding of thermochemical principles and the properties of particles and substances

AS91390 (la) External 5 credits

Demonstrate understanding of the properties of organic compounds

AS91391 (la) External 5 credits

Demonstrate understanding of equilibrium principles in aqueous systems

AS91392 (lna) UEna External 5 credits

Demonstrate understanding of oxidation-reduction processes

AS91393 (la) Internal 3 credits

Chinese

Te Reo Hainamana

Not only is Chinese one of the oldest living languages but it is a major world language spoken across the globe by over one billion of people. As the New Zealand population diversifies, Chinese is becoming a major language in this country while remaining highly important for trade and tourism. For some, the history and very look of its written characters are fascinating, while for others it is a chance to stay in touch with their own family background. This subject focuses on both spoken and written modern standard Chinese (Mandarin) which is used throughout China, Singapore and Taiwan. It also explores the culture of Chinese speaking countries.

ZH000

Beginners' Chinese

Curriculum Level 1–5

A beginners' course in modern standard Chinese (Mandarin), where students will practise everyday listening and speaking skills, plus reading and writing the Pinyin alphabetical system and some simple characters. They will learn: simple greetings, how to introduce themselves and family members, how to find their way around town, arrange meetings, book travel arrangements, and offer and accept hospitality. They will learn around 200 characters in this course. They will also find out about life and customs in China. The course can be taken over one or two years. We recommend students who want to do NCEA Level 1 should take this course first.

Recommended prior learning: No prior learning needed.

This is an online course so access to a computer and broadband internet is essential. Some materials may be downloadable booklets in PDF format or sent to you through the post. Read more on our website at www.tekura.school.nz

If you are a secondary dual student, you must have access to a computer to download the PDF course booklets.

For this course you will be required to make and submit audio and/or video recordings, so a microphone – either separate or built into your device – is essential.

ZH1000

Chinese

NCEA Level 1 (course endorsement available)

This course builds on language already covered in ZH000. It will develop students' listening and speaking skills in modern standard Chinese (Mandarin), plus reading and writing of simplified characters, with Pinyin used as a means of extending the range of language used. By the end of this course students will be able to read and recognise around 370 characters and write 220 characters. Students

will be required to translate, listen and engage with language as much as possible. The Chinese language and its relationship with life and customs in China is highlighted, and topics include things such as folk stories and legends, sport, food and festivals, with students also learning how to communicate the time, direction, seasons and their daily routine.

Recommended prior learning: Students should have reading and writing knowledge of about 100 Chinese characters.

This course is only available in our Online Teaching and Learning Environment (OTLE). It includes a mix of interactive online modules and downloadable booklets in PDF format, so access to a computer and broadband internet is essential. Some assessment activities may be sent to you through the post. Read more on our website at www.tekura.school.nz

If you are a secondary dual student, you must have access to a computer to download the PDF course booklets.

For this course you will be required to make and submit audio and/or video recordings, so a microphone – either separate or built into your device – is essential.

Demonstrate understanding of a variety of spoken Chinese texts on areas of most immediate relevance

AS90868 Pr Se So Cr External 5 credits

Give a spoken presentation in Chinese that communicates a personal response

AS90869 Pr Internal 4 credits

Demonstrate understanding of a variety of Chinese texts on areas of most immediate relevance

AS90871 Se External 5 credits

Write a variety of text types in Chinese on areas of most immediate relevance

AS90872 Se Cr Internal 5 credits

ZH2000**Chinese**

NCEA Level 2 (course endorsement available)

This course builds on language already mastered for level 1. General listening and speaking skills are further developed, plus students' ability to read and write simplified characters will be expanded. Over the year, students will learn how to communicate information about themselves and their friends, their home country and future plans, as well as how to write a CV. As with previous courses, a focus on Chinese culture is emphasised, and issues surrounding living in a foreign country and their customs and behaviour are covered.

Recommended prior learning: NCEA Level 1 Chinese or equivalent.

This course is booklet-based – you may download booklets in PDF format from our Online Teaching and Learning Environment (OTLE) or receive printed booklets through the post to complete and return for assessment.

If you are a secondary dual student, you must have access to a computer to download the PDF course booklets.

There are some optional supplementary online resources for this course which would be beneficial for your learning. Access to a computer and the internet is essential for these resources.

For this course you will be required to make and submit audio and/or video recordings, so a microphone – either separate or built into your device – is essential.

Demonstrate understanding of a variety of spoken Chinese texts on familiar matters

AS91108 Se Cr External 5 credits

Interact using spoken Chinese to share information and justify ideas and opinions in different situations

AS91109 SSe So Cr Internal 5 credits

Give a spoken presentation in Chinese that communicates information, ideas and opinions

AS91110 Internal 4 credits

Demonstrate understanding of a variety of written and/or visual Chinese text(s) on familiar matters

AS91111 Se External 5 credits

Write a variety of text types in Chinese to convey information, ideas, and opinions in genuine contexts

AS91112 Se Cr Internal 5 credits

ZH3000**Chinese**

NCEA Level 3 (course endorsement available)

Level 3 and Scholarship Chinese will develop students' ability to communicate in Chinese in a variety of situations. Throughout the course, opportunities are provided to listen to and speak Chinese, as well as to read and write using simplified characters to an advanced level. Students will learn not only how to express a point of view, but also how to support an argument or provide suggestions. Chinese culture is also considered, in particular the matter of cultural differences, and the skills and advice required to plan a trip to China will be covered.

New Zealand Scholarship exams are designed to extend very high achieving level 3 students. Those who wish to enter for the NZ Scholarship exam in this subject must discuss this option with their Te Kura subject teacher.

Recommended prior learning: NCEA Level 2 Chinese or equivalent.

This course is booklet-based – you may download booklets in PDF format from our Online Teaching and Learning Environment (OTLE) or receive printed booklets through the post to complete and return for assessment.

For this course you will be required to make and submit audio and/or video recordings, so a microphone – either separate or built into your device – is essential. If you are a secondary dual student, you must have access to a computer to download the PDF course booklets.

Demonstrate understanding of a variety of extended spoken Chinese texts

AS91533 External 5 credits

Give a clear spoken presentation in Chinese that communicates a critical response to stimulus material

AS91534 Internal 3 credits

Interact clearly using spoken Chinese to explore and justify varied ideas and perspectives in different situations

AS91535 Internal 6 credits

Demonstrate understanding of a variety of extended written and/or visual Chinese texts

AS91536 External 5 credits

Write a variety of text types in clear Chinese to explore and justify varied ideas and perspectives

AS91537 Internal 5 credits

Classical Studies

Te Akoranga Puāwaitanga

Many of Western culture's roots can be traced back to Ancient Greece and Rome. Classical Studies looks into the lives, beliefs and creations of the people of these civilisations. Not only has our literature, language, art and architecture been developed from the classical world, but much of our science, mathematics, laws and systems of government as well. Therefore by comparing our ways of living with these origins, we can gain a greater understanding of the current world and its influences. The subject is multi-disciplinary, covering topics from politics to religion and philosophy. Students will gain a wide range of historical knowledge and cultural insight while developing their analytical, critical and research skills.

GL2000

Classical Studies

NCEA Level 2 (course endorsement available)

An introduction to the classical world, where students will learn about Ancient Greek and Roman art, beliefs and literature. This includes a study of classical mythology, Homer's epic poem 'The Odyssey' and Greek tragedy. The golden age of Greece is foreshadowed in a study of the Persian Wars. The change from the Republic to the Empire in Rome is studied in 'The Death of Caesar'.

There are also 12 credits of Religious Studies assessments available. Religious Studies is an approved UE subject. It is research-based and all material is available from the internet. Contact your teacher for further information.

Recommended prior learning: Students should have a good level of literacy.

This course is booklet-based – you may download booklets in PDF format from our Online Teaching and Learning Environment (OTLE) or receive printed booklets through the post to complete and return for assessment.

If you are a secondary dual student, you must have access to a computer to download the PDF course booklets.

There are some optional supplementary online resources for this course which would be beneficial for your learning. Access to a computer and the internet is essential for these resources.

Religious Studies

Explain the changes in an expression(s) of a religious tradition

AS90821 (1a) Internal 6 credits

Explain the key beliefs within two religious traditions in relation to a significant religious question

AS90823 (1a) Internal 6 credits

Classical Studies

Examine ideas and values of the classical world

AS91200 (1a) UElwra SCr External 4 credits

Examine the significance of features of work(s) of art in the classical world

AS91201 (1a) UElwra Se SCr External 4 credits

Demonstrate understanding of a significant event in the classical world

AS91202 (1a) UElra SCr Internal 4 credits

Examine socio-political life in the classical world

AS91203 (1a) UElwra SCr External 6 credits

Demonstrate understanding of the relationship between aspects of the classical world and aspects of other cultures

AS91204 (1a) UElra SCr Internal 6 credits

GL3000

Classical Studies

NCEA Level 3 (course endorsement available)

Theatre and literature form a large part of this course, and their relation to life in Ancient Greece and Rome. Importantly, these still influence us today, with much Western drama and fiction originating from this time. Students will encounter the Greek Attic comedy of Aristophanes, as well as Virgil's epic poem 'The Aeneid'. In turn, an introduction to the concepts behind Greek vase painting and a historical study of Alexander the Great is also offered. Throughout the course, students will gain further insight into not just ancient culture but the way we act, think and live today.

There are also 18 credits of Religious Studies assessments available. Religious Studies is an approved UE subject. It is research-based and all material is available from the internet. Contact your teacher for further information.

Recommended prior learning: Students should have a very good level of literacy.

This course is booklet-based – you may download booklets in PDF format from our Online Teaching and Learning Environment (OTLE) or receive printed booklets through the post to complete and return for assessment.

If you are a secondary dual student, you must have access to a computer to download the PDF course booklets.

There are some optional supplementary online resources for this course which would be beneficial for your learning. Access to a computer and the internet is essential for these resources.

Religious Studies

Analyse the meanings in a sacred text within a religious tradition

AS91725 (la) UElra Internal 6 credits

Analyse the response of a religious tradition to a contemporary ethical issue

AS90826 (la) UElra Internal 6 credits

Analyse the key beliefs of a religious tradition and a secular world view in relation to ultimate questions

AS90827 (la) UElra Internal 6 credits

Classical Studies

Analyse ideas and values of the classical world

AS91394 (la) UElwra External 4 credits

Analyse the significance of a work(s) of art in the classical world

AS91395 (la) UElwra External 4 credits

Analyse the impact of a significant historical figure on the classical world

AS91396 (la) UElwra External 6 credits

Demonstrate understanding of significant ideology(ies) in the classical world

AS91397 (la) UElra Internal 6 credits

Demonstrate understanding of the lasting influences of the classical world on other cultures across time

AS91398 (la) UElra Internal 6 credits

Commerce Studies

Te Mātauranga Tauhokohoko

Commerce Studies offers students the opportunity to learn about specialist commerce subjects by choosing from a broad range of topics that match their interests and passion. Students select topics from Accounting, Business Studies, Economics and/or Legal Studies. If students enjoy a particular subject this can take them to further study of the specialist subject.

CMI000

Commerce Studies

NCEA Level 1 (course endorsement not available)

This course offers a range of topics from level 1 Accounting, Economics, Business Studies and Legal Studies. It is designed for students who are unable to sit external exams due to particular circumstances. It offers internally assessed standards only and students are recommended to select approximately 18–20 credits. Note that this course does not offer course endorsement as students will not have the opportunity to sit external exams.

Recommended prior learning: Students should have a reasonable level of literacy.

This course is only available in our Online Teaching and Learning Environment (OTLE). It includes a mix of interactive online modules and downloadable booklets in PDF format, so access to a computer and broadband internet is essential. Some assessment activities may be sent to you through the post. Read more on our website at www.tekura.school.nz

Identify and describe basic employment rights and responsibilities, and sources of information and assistance

US1978 Pr So Internal 3 credits

Demonstrate knowledge of accessing legal assistance

US8548 Pr So Cr Internal 2 credits

Demonstrate knowledge of enterprising behaviour, innovation, and entrepreneurship in business contexts

US22847 Cr Internal 2 credits

Apply the marketing mix to a new or existing product

AS90840 (la) Pr Se Cr Internal 3 credits

Investigate aspects of human resource processes in a business

AS90841 (la) Pr Cr Internal 3 credits

Prepare financial information for a community organisation's annual general meeting

AS90979 (la) Se Cr Internal 4 credits

Make a financial decision for an individual or group

AS90981 (la) Se Cr Internal 3 credits

Demonstrate understanding of cash management for a small entity

AS90982 (la) Se Cr Internal 4 credits

Demonstrate understanding of decisions a producer makes about production

AS90984 (la) Pr Se Cr Internal 5 credits

Demonstrate understanding of a government choice where affected groups have different viewpoints

AS90987 (la) Pr Se Cr Internal 4 credits

Demonstrate understanding of the interdependence of sectors of the New Zealand economy

AS90988 (la) Pr Se So Cr Internal 3 credits

CM2000

Commerce Studies

NCEA Level 2 (course endorsement not available)

This course offers a range of topics from level 2 Accounting, Economics, Business Studies and Legal Studies. It is designed for students who are unable to sit external exams due to particular circumstances. It offers internally assessed standards only and students are recommended to select approximately 18–20 credits. Note that this course does not offer course endorsement as students will not have the opportunity to sit external exams. If students wish to progress to level 3 Accounting, further learning may be required.

Recommended prior learning: Students should have a reasonable level of literacy.

This course is booklet-based – you may download booklets in PDF format from our Online Teaching and Learning Environment (OTLE) or receive printed booklets through the post to complete and return for assessment.

If you are a secondary dual student, you must have access to a computer to download the PDF course booklets.

There are some optional supplementary online resources for this course which would be beneficial for your learning. Access to a computer and the internet is essential for these resources.

Demonstrate and apply knowledge of office equipment and administration processes

US121 SSe Cr Internal 5 credits

Describe factors contributing to, and consequences of, crime

US8545 SSo Internal 3 credits

Describe the objectives and application of consumer law

US8555 So Cr Internal 3 credits

Describe the legal rights and personal responsibilities of secondary school students

US10337 So Internal 3 credits

Conduct market research for a new or existing product

AS90846 (Ina) UEna Pr Se Cr Internal 3 credits

Investigate the application of motivation theory in a business

AS90847 (Ia) Se Cr Internal 3 credits

Demonstrate understanding of accounting processing using accounting software

AS91175 (na) UEna Se Cr Internal 4 credits

Demonstrate understanding of an accounts receivable subsystem for an entity

AS91179 (Ina) UEna Cr Internal 3 credits

Analyse unemployment using economic concepts and models

AS91225 (Ia) Cr Internal 4 credits

Analyse statistical data relating to two contemporary economic issues

AS91226 (Ina) UEna Se Cr Internal 4 credits

Demonstrate understanding of an inventory subsystem for an entity

AS91386 (Ina) UEna Cr Internal 3 credits

Demonstrate understanding of a contemporary accounting issue for decision-making

AS91481 (Ia) Cr Internal 4 credits

Design and Visual Communication

Ngā mahi hoahoa me te Whakawhitiwhiti ataata

This subject is for students interested in design and drawing. Design and Visual Communication, also known as Graphics, develops students' visual communication skills and design thinking to explore and solve design problems. Students will develop skills in sketching, rendering, drawing and modelling to explore, communicate and present their ideas. In some topics, students will be able to have models of their design work 3D printed by Te Kura. Students are encouraged to generate creative and innovative solutions to solve design problems that are set in authentic contexts, and can be customised to suit their interests.

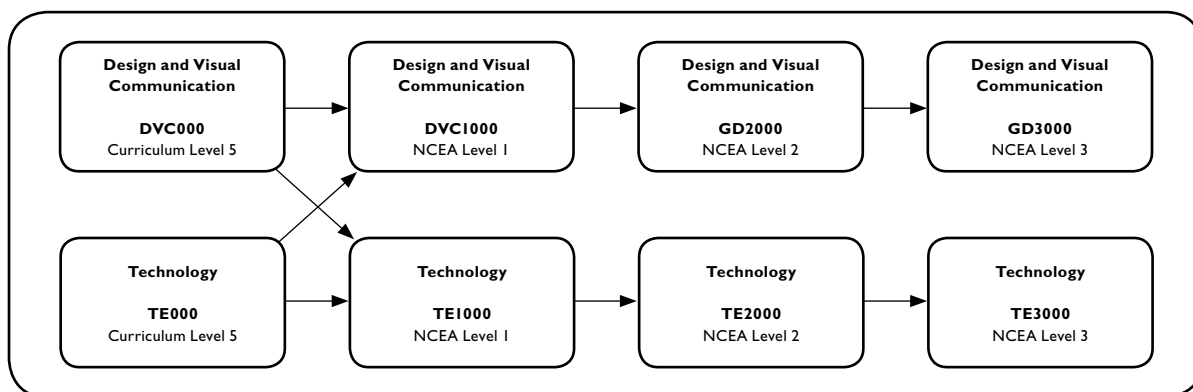

DVC000

Design and Visual Communication

Curriculum Level 5

This introductory course will appeal to any student who enjoys sketching and is interested in the challenge of solving design problems. Students will learn design and drawing techniques, which will enable them to design everyday objects and present them visually, including having a model 3D printed. Students will include influences from their cultural and physical contexts in their design projects. Topics include product and spatial design, sketching, rendering, modelling and instrumental drawing.

Recommended prior learning: No prior learning needed.

This is an online course so access to a computer and broadband internet is essential. Read more on our website at www.tekura.school.nz

DVC1000

Design and Visual Communication

NCEA Level 1 (course endorsement available)

This course develops students' visual communication and design skills. Students start the course exploring the influence of a significant designer and then move on to two major design projects, in the contexts of product design and spatial design. The design briefs are customisable to reflect individual students' interests and passions. Interspersed in the projects are exercises to develop students' technical skills. An optional topic develops presentation techniques. The work done in these projects contributes to internally assessed standards and a portfolio for external assessment.

Recommended prior learning: No prior learning needed.

This course is only available in our Online Teaching and Learning Environment (OTLE). It includes a mix of interactive online modules and downloadable booklets in PDF format, so access to a computer and broadband internet is essential. Some assessment activities may be sent to you through the post. Read more on our website at www.tekura.school.nz

Produce freehand sketches that communicate design ideas

AS91063

Co Ma Cr

External 3 credits

Produce instrumental, multi-view orthographic drawings that communicate technical features of design ideas

AS91064 (na) UEna Co Ma Cr External 3 credits

Produce instrumental paraline drawings to communicate design ideas

AS91065 (na) UEna Co Ma Cr External 3 credits

Use rendering techniques to communicate the form of design ideas

AS91066 Co Ma Cr Internal 3 credits

Use the work of an influential designer to inform design ideas

AS91067 Ma Cr Internal 3 credits

Undertake development of design ideas through graphics practice

AS91068 Co Ma Cr Internal 6 credits

Promote an organised body of design work to an audience using visual communication techniques

AS91069 (la) Co Ma Cr Internal 4 credits

GD2000

Design and Visual Communication

NCEA Level 2 (course endorsement available)

This course develops students' understanding of practices specific to product and spatial designers through two major design projects, customised to reflect their personal interests. Students are challenged to examine solutions to design problems in greater depth. Interspersed in the projects are exercises to advance students' technical skills. The work done in these projects contributes to internally assessed standards and a portfolio for external assessment. For design focussed students, optional topics explore the influence of significant design movements and presentation techniques. For technically oriented students, optional topics focus on orthographic and perspective drawing.

Recommended prior learning: NCEA Level 1 Graphics or equivalent.

This course is booklet-based – you may download booklets in PDF format from our Online Teaching and Learning Environment (OTLE) or receive printed booklets through the post to complete and return for assessment.

If you are a secondary dual student, you must have access to a computer to download the PDF course booklets.

There are some optional supplementary online resources for this course which would be beneficial for your learning. Access to a computer and the internet is essential for these resources.

Use visual communication techniques to generate design ideas

AS91337 SCo Ma Pr Se SCr External 3 credits

Produce working drawings to communicate technical details of a design

AS91338 SCo SMa Pr SCr External 4 credits

Produce instrumental perspective projection drawings to communicate design ideas

AS91339 SCo SMa SCr External 3 credits

Use the characteristics of a design movement or era to inform own design ideas

AS91340 SCr Internal 3 credits

Develop a spatial design through graphics practice

AS91341 (la) SCo Ma SCr Internal 6 credits

Develop a product design through graphics practice

AS91342 SCo SMa SCr Internal 6 credits

Use visual communication techniques to compose a presentation of a design

AS91343 SCo Ma Se SCr Internal 4 credits

GD3000

Design and Visual Communication

NCEA Level 3 (course endorsement available)

This online course covers NCEA Level 3 and Scholarship. Students will develop their own design briefs, based on authentic situations in the contexts of spatial and product design. They will be challenged to generate innovative and creative design ideas and carry them through to highly resolved design solutions. During this process they will participate in online discussions and critiques, submitting their work digitally. Students will work in a range of different media, both paper-based and digital, and can have some models 3D printed by Te Kura. Final assessments are paper based, and submitted by post. Access to a digital camera or scanner is essential.

Recommended prior learning: NCEA Level 2 Design and Visual Communication or equivalent.

This is an online course, so access to a computer and broadband internet is essential. Read more on our website at www.tekura.school.nz

Initiate design ideas through exploration

AS91627 External 4 credits

Develop a visual presentation that exhibits a design outcome to an audience

AS91628 Internal 6 credits

Resolve a spatial design through graphics practice

AS91629 Internal 6 credits

Resolve a product design through graphics practice

AS91630 Internal 6 credits

Digital Technology

Te Hangarau Mamatai

Digital Technology equips students with knowledge and skills to participate in a rapidly changing digital environment. Courses are designed to develop students' digital understanding and to equip them with the expertise needed to be capable digital citizens. Courses offer students opportunities to develop their interests and expertise in web design, programming, data management, spreadsheets, and desktop publishing.

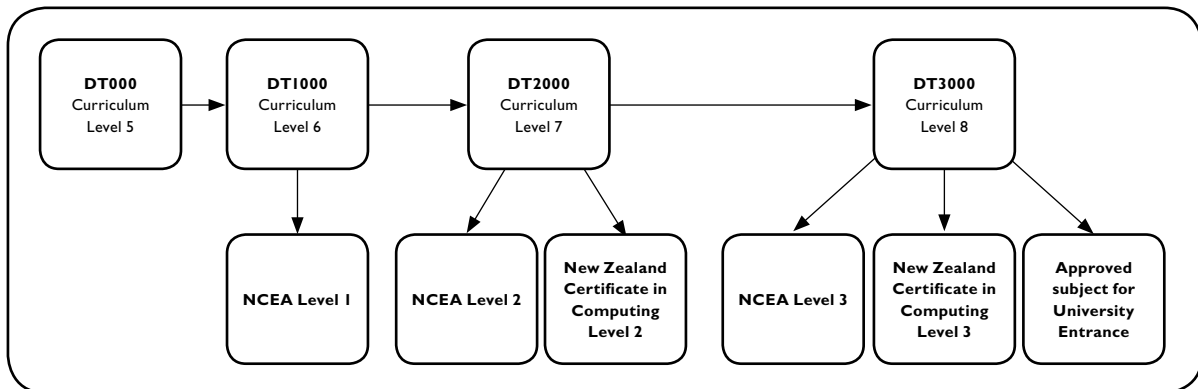

DT000

Digital Technology

Curriculum Level 5

This course offers a wide range of different digital learning opportunities that will appeal to all students. Activities are exciting and are based on student interest. The focus is on creativity as students are guided to participate in a digital environment that they are responsible for creating. Students will be introduced to web design, coding and programming, design, digital imaging, computer science, cyber safety, and how to become better digital citizens.

Recommended prior learning: No prior learning needed.

This is an online course so access to a computer and broadband internet is essential. Read more on our website at www.tekura.school.nz

Recommended prior learning: No prior learning needed.

This is an online course, so access to a computer and broadband internet is essential. Read more on our website at www.tekura.school.nz

Develop and use keyboarding skills to enter text

US101 Pr So Internal 3 credits

Consolidate keyboarding skills and produce accurate text based documents

US102 Pr So Internal 3 credits

Demonstrate and apply knowledge of a personal computer system

US2780 Pr Cr Internal 3 credits

Manage and protect data in a personal computer

US2781 Co Ma So Cr Internal 3 credits

Produce simple desktop published documents using templates

US2792 Ma Pr Cr Internal 2 credits

Use computer technology to create and deliver a presentation from given content

US5946 Ma Cr Internal 3 credits

Demonstrate an understanding of ergonomic principles for computer workstations

US6743 Ma Cr Internal 2 credits

Enter and manage text for generic text and information management

US12883 Pr So Internal 4 credits

DT1000

Digital Technology

NCEA Level 1 (course endorsement available)

This course offers a wide range of different digital learning opportunities that will appeal to all students. Activities are exciting and are based on student interest. The focus is on creativity as students are guided to participate in a digital environment that they are responsible for creating. Students will be introduced to web design, coding and programming, design, digital imaging, computer science, cyber safety and how to become better digital citizens.

Produce a spreadsheet from instructions using supplied data

US18743 Ma Pr So Cr Internal 2 credits

Produce still images for a range of digital media

US26745 Ma Cr Internal 3 credits

Implement basic procedures to produce a specified digital information outcome

AS91071 Ma Pr Se So Cr Internal 4 credits

Demonstrate understanding of basic concepts of digital media

AS91072 (la) Ma Pr Se Cr Internal 3 credits

Implement basic procedures to produce a specified digital media outcome

AS91073 Ma Pr Se Cr Internal 4 credits

Demonstrate understanding of basic concepts from computer science

AS91074 (la) Ma Pr Cr External 3 credits

Construct a plan for a basic computer program for a specified task

AS91075 Ma Cr Internal 3 credits

Construct a basic computer program for a specified task

AS91076 Ma Cr Internal 3 credits

DT2000

Digital Technology

NCEA Level 2 (course endorsement available)

This online level 2 course offers students the opportunity to further explore programming, web design and other topics studied in DT1000. The topics can be studied in any order, but it is recommended that students who are interested in gaining the NZ National Certificate in Computing Level 2 only complete the topics where Unit Standards are offered.

Recommended prior learning: No prior learning needed.

This is an online course, so access to a computer and broadband internet is essential. Read more on our website at www.tekura.school.nz

Use a word processor to produce documents for a business or organisation

US111 Se So Internal 5 credits

Manage and protect data in a personal computer

US2781 Co Ma So Cr Internal 3 credits

Create and use a computer spreadsheet to solve a problem

US2784 Co Ma Pr Se So Cr Internal 3 credits

Produce desktop published documents to meet a set brief

US2788 Co Ma SCr Internal 5 credits

Integrate spreadsheet and database data into word processed documents to meet a set brief

US2791 Co Ma Pr Cr Internal 3 credits

Produce a presentation using a desktop presentation computer application

US5940 Co Ma SCr Internal 3 credits

Demonstrate an understanding of ergonomic principles for computer workstations

US6743 Ma Cr Internal 2 credits

Create a website using a mark-up language to meet a set brief

US25656 Ma SCr Internal 3 credits

Demonstrate understanding of advanced concepts relating to managing shared information within information systems

AS91367 (la) SMa Pr Se Cr External 3 credits

Implement advanced procedures to produce a specified digital media outcome

AS91370 SMa Se SCr Internal 4 credits

Demonstrate understanding of advanced concepts from computer science

AS91371 (la) SMa SCr External 4 credits

Construct an advanced computer program for a specified task

AS91373 SMa SCr Internal 3 credits

Demonstrate understanding of local area network technologies

AS91377 (la) SMa Cr Internal 3 credits

DT3000

Digital Technology

NCEA Level 3 (course endorsement available)

This is an online level 3 course and an approved University Entrance subject. Students can explore topics such as brief development, conceptual design, desktop publishing, web design and spreadsheets. It is recommended that students aiming for UE complete the topics where Achievement Standards are being offered and students who want to gain the NZ National Certificate in Computing Level 3 complete topics where Unit Standards are being offered.

Recommended prior learning: DT2000 topics recommended.

This is an online course, so access to a computer and broadband internet is essential. Read more on our website at www.tekura.school.nz

Create a computer spreadsheet to provide a solution for organisation use

US2785 Internal 5 credits

Create and use a computer database to provide a solution for organisation use

US2787 Internal 6 credits

Produce desktop published documents for organisation use

US2789 Internal 6 credits

Demonstrate knowledge of the principles of computer networks

US2797 Internal 4 credits

Demonstrate understanding of complex concepts of digital media

AS91634 (la) Internal 4 credits

Implement complex procedures to produce a specified digital media outcome

AS91635 (la) Internal 4 credits

Demonstrate understanding of areas of computer science

AS91636 (la) UElwra External 4 credits

Demonstrate understanding of wide area network technologies

AS91641 (la) UElra Internal 4 credits

Early Childhood

Te Reanga Kōhungahunga

The Early Childhood Service offers a high-quality, individualised early education programme to children aged from 2–6 years. The programme works within the guidelines of Te Whāriki, the New Zealand Early Childhood Curriculum, and is available free of charge to students who qualify under any of the entry criteria.

Through the programme, parents (or caregivers) and teachers work together to share information about children’s learning and development, with this knowledge informing the development of the child’s programme of learning. Resources including books, puzzles, games, art materials and CDs are sent with each posting. Children are able to attend a licensed early childhood centre for up to eight hours per week and still qualify for Te Kura.

Economics

Te Mātauranga Ōhanga

Economics is a social science and is about people and how they use resources. By studying economics students will become aware of the role that everyone plays in an economy, while increasing their understanding of economic events and improving their own decision-making. Students will explore the interactions between producers, consumers and government and the impact economic decisions can have on society. Economics encourages students to think critically and independently about business, economic and social issues. This subject leads to careers in a range of fields including social policy and planning, business and financial management.

EC1000

Economics

NCEA Level 1 (course endorsement available)

In this course students learn about producer and consumer choices, interactions between households and firms, how economic decisions are made, and the effects these choices have on individuals and the economy.

Students will be introduced to the way producers work and the concept of a market which determines prices and allocates scarce resources. We are all involved in economics as producers or consumers and this course provides an understanding of our different roles in this process.

Recommended prior learning: Students should have a reasonable level of literacy.

This course is only available in our Online Teaching and Learning Environment (OTLE). It includes a mix of interactive online modules and downloadable booklets in PDF format, so access to a computer and broadband internet is essential. Some assessment activities may be sent to you through the post. Read more on our website at www.tekura.school.nz

Demonstrate understanding of consumer choices, using scarcity and/or demand

AS90983 (la) Pr Se Cr External 4 credits

Demonstrate understanding of decisions a producer makes about production

AS90984 (la) Pr Se Cr Internal 5 credits

Demonstrate understanding of producer choices using supply

AS90985 (la) Pr Se Cr External 3 credits

Demonstrate understanding of how consumer, producer and/or government choices affect society, using market equilibrium

AS90986 (la) Pr Se Cr External 5 credits

Demonstrate understanding of a government choice where affected groups have different viewpoints

AS90987 (la) Pr Se Cr Internal 4 credits

Demonstrate understanding of the interdependence of sectors of the New Zealand economy

AS90988 (la) Pr Se So Cr Internal 3 credits

EC2000

Economics

NCEA Level 2 (course endorsement available)

This course gives students the opportunity to explore major economic issues such as economic growth, unemployment, trade and inflation. They develop the skills to define and measure these and analyse their causes and effects in the context of the New Zealand economy.

Students learn to use and evaluate economic models. The role of the government in the economy and the consequences of government policies are also explored. Students examine the interdependent nature of economies and compare and contrast the varying impacts of economic forces on different groups in society, thereby gaining greater understanding of economic events and trends.

Recommended prior learning: Students should have a reasonable level of literacy.

This course is booklet-based – you may download booklets in PDF format from our Online Teaching and Learning Environment (OTLE) or receive printed booklets through the post to complete and return for assessment.

If you are a secondary dual student, you must have access to a computer to download the PDF course booklets.

There are some optional supplementary online resources for this course which would be beneficial for your learning. Access to a computer and the internet is essential for these resources.

Analyse inflation using economic concepts and models
AS91222 (la) UElwa Se Cr External 4 credits

Analyse international trade using economic concepts and models
AS91223 (la) UElwa Pr Se Cr External 4 credits

Analyse economic growth using economic concepts and models
AS91224 (la) UElwa Se Cr External 4 credits

Analyse unemployment using economic concepts and models
AS91225 (la) Cr Internal 4 credits

Analyse statistical data relating to two contemporary economic issues
AS91226 (lna) UEna Se Cr Internal 4 credits

Analyse how government policies and contemporary economic issues interact
AS91227 (la) UElra Se So Cr Internal 6 credits

EC3000

Economics

NCEA Level 3 (course endorsement available)

This course will develop and improve economic understanding of a range of social and economic issues.

There are three main areas of study. The first is based around resource allocation and the market and will look closely at the concepts of scarcity and opportunity cost, demand and supply, market analysis, and monopolies and other market structures. The second section explores situations of market failure and looks at the role of government in the economy in correcting market failure. The third section looks at influences on the New Zealand economy as a whole, both internal and external, including the aims of government and the effects of government policies.

New Zealand Scholarship exams are designed to extend very high achieving level 3 students. Those who wish to enter for the NZ Scholarship exam in this subject must discuss this option with their Te Kura subject teacher.

Recommended prior learning: Students should have a reasonable level of literacy.

This course is booklet-based – you may download booklets in PDF format from our Online Teaching and Learning Environment (OTLE) or receive

printed booklets through the post to complete and return for assessment.

If you are a secondary dual student, you must have access to a computer to download the PDF course booklets.

There are some optional supplementary online resources for this course which would be beneficial for your learning. Access to a computer and the internet is essential for these resources.

Demonstrate understanding of the efficiency of market equilibrium

AS91399 (la) UElwra External 4 credits

Demonstrate understanding of the efficiency of different market structures using marginal analysis

AS91400 (la) UElwra External 4 credits

Demonstrate understanding of micro-economic concepts

AS91401 (la) UElra Internal 5 credits

Demonstrate understanding of government interventions to correct market failures

AS91402 (la) UElra Internal 5 credits

Demonstrate understanding of macro-economic influences on the New Zealand economy

AS91403 (la) UElwra External 6 credits

English

Te Reo Ingarihi

English is one of the three official languages of New Zealand. It is an essential tool for full participation in our personal, local, national and global communities. At Te Kura, the study of English will support students to extend their competency in the use of language in a variety of contexts including tertiary study and the workplace. Through the study of literature, students will develop a sense of their identity as New Zealanders and explore their heritage. They will also develop critical thinking skills which will enable them to evaluate and challenge the thinking of others, as well as contributing to the global debate.

English is structured to allow maximum flexibility in course design. Students follow a course that is linked to their learning needs and goals. They progress through the levels at their own pace. For NCEA, students select a pathway to follow but can change pathways at any time. Students are able to access the three literacy unit standards in all NCEA courses. The LY1500 course is for Adult and Young Adult students who only want literacy.

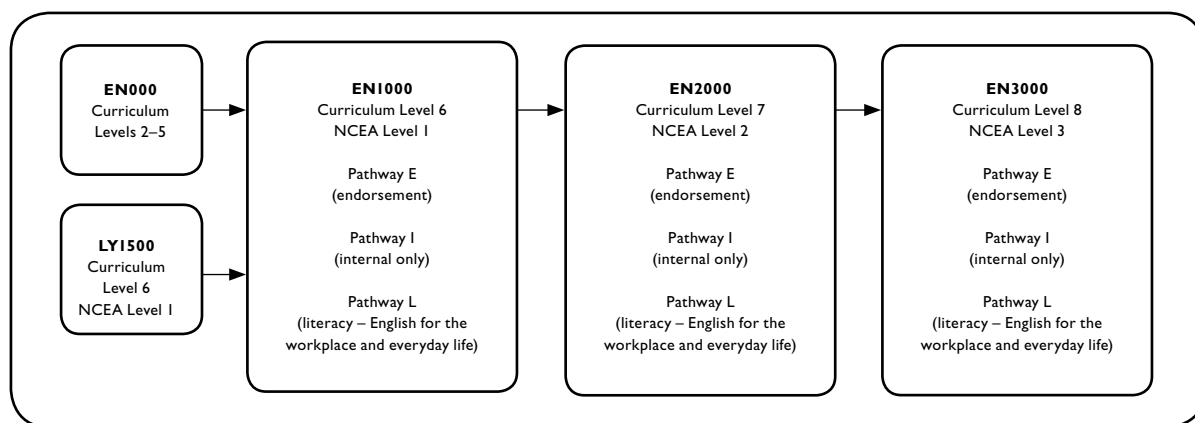

EN000

English

Curriculum Levels 2–5

This course is suited to students who are working at Curriculum Levels 2–5 in English and is personalised to meet individual learning needs. All aspects of English are covered, from reading, writing and speaking, through to listening, viewing and image-making exercises. This course aims to develop the skills required for progression to NCEA English.

Recommended prior learning: No prior learning needed.

This is an online course so access to a computer and broadband internet is essential. Read more on our website at www.tekura.school.nz

EN1000

English

NCEA Level 1 (course endorsement available)

EN1000 is the course for all students taking English for level 1. The focus is on skills in ‘making and creating meaning’, through a range of texts in written, visual and oral forms. In level 1 our skills reflect the sophistication of the text and our audience through the development of ideas and explanations.

Within the course a student can take one of several pathways depending on their goals, interests and skills. Students can alter their path at any time. All standards are available to all students including the literacy unit standards.

Here are the initial options:

- E. (Endorsement) A full NCEA programme with the opportunity to gain endorsement at the Merit or Excellence levels – internal and external standards.
- I. (Internal) An internal standards course with a focus on literature and communication.

L. (Literacy – English for work and everyday life)
A combination of achievement standards and unit standards that develop communication skills in practical contexts.

The initial choice will determine the first materials students will be sent. Students will then plan their programme in consultation with their teacher.

Recommended prior learning: Working at Curriculum Levels 5–6 in English.

This course is only available in our Online Teaching and Learning Environment (OTLE). It includes a mix of interactive online modules and downloadable booklets in PDF format, so access to a computer and broadband internet is essential. Some assessment activities may be sent to you through the post. Read more on our website at www.tekura.school.nz

Express ideas in writing and write an original story

US1273 Pr Cr Internal 4 credits

Be interviewed in an informal one-to-one, face-to-face interview

US1293 Ma Pr So Cr Internal 2 credits

Fill in a form

US3483 Pr So Cr Internal 2 credits

Complete an incident report

US3490 Pr So Cr Internal 2 credits

Demonstrate knowledge of and apply listening techniques

US3501 Pr So Cr Internal 3 credits

Write formal personal correspondence

US10792 Pr Cr Internal 3 credits

Independently read texts for practical purposes and to gain knowledge

US25060 Pr Cr Internal 6 credits

Write to communicate ideas for a purpose and audience

US26622 (lu) Internal 4 credits

Read texts with understanding

US26624 (lu) Internal 3 credits

Actively participate in spoken interactions

US26625 (lu) Internal 3 credits

Produce creative writing

AS90052 (la) Co Ma Pr Se So Cr Internal 3 credits

Produce formal writing

AS90053 (la) Co Ma Pr Se So Cr Internal 3 credits

Show understanding of specified aspect(s) of studied written text(s), using supporting evidence

AS90849 (la) Co Ma Pr Se So Cr External 4 credits

Show understanding of specified aspect(s) of studied visual or oral text(s), using supporting evidence

AS90850 (la) Co Ma Pr Se So Cr External 4 credits

Show understanding of significant aspects of unfamiliar written text(s) through close reading, using supporting evidence

AS90851 (la) Co Ma Pr Se So Cr External 4 credits

Explain significant connection(s) across texts, using supporting evidence

AS90852 (la) Co Ma Pr Se So Cr Internal 4 credits

Use information literacy skills to form conclusion(s)

AS90853 (la) Co Ma Pr Se So Cr Internal 4 credits

Form personal responses to independently read texts, supported by evidence

AS90854 (la) Co Ma Pr Se So Cr Internal 4 credits

Create a visual text

AS90855 (la) Co Ma Pr Se So Cr Internal 3 credits

Show understanding of visual and/or oral text(s) through close viewing and/or listening, using supporting evidence

AS90856 (la) Co Ma Pr Se So Cr Internal 3 credits

Construct and deliver an oral text

AS90857 (la) Co Ma Pr Se So Cr Internal 3 credits

EN2000

English

NCEA Level 2

EN2000 is the course for all students taking English for level 2. The focus is on skills in 'making and creating meaning', through a range of texts in written, visual and oral forms. At level 2 our skills reflect the sophistication of the text and our audience through analysis.

Within the course a student can take one of several pathways depending on their goals, interests and skills. Students can alter their path at any time. All standards are available to all students.

Here are the initial options:

- E. (Endorsement) A full NCEA programme with the opportunity to gain endorsement at the Merit or Excellence levels – internal and external standards.
- I. (Internal) A focus on meeting the University Entrance literacy requirement (five reading and five writing credits) with internal standards.
- L. (Literacy – English for work and everyday life) A combination of achievement standards and unit standards that develop communication skills in practical contexts.

The initial choice will determine the first materials students will be sent. Students will then plan their programme in consultation with their teacher.

We encourage students, wherever possible, to work in the OTLE environment. English is structured to allow maximum flexibility in course design. Students follow a course that is linked to their learning needs and goals. They progress through the levels at their own pace.

For NCEA, students select a pathway to follow but can change pathways at any time. Students are able to access the three literacy unit standards in all NCEA courses. The LY1500 course is for Adult and Young Adult students who only want literacy.

Recommended prior learning: NCEA Level 1 or equivalent in English.

This course is booklet-based – you may download booklets in PDF format from our Online Teaching and Learning Environment (OTLE) or receive printed booklets through the post to complete and return for assessment.

If you are a secondary dual student, you must have access to a computer to download the PDF course booklets.

You may also be sent audio CDs, DVDs, equipment and/or materials through the post.

Communicate information in a specified workplace

US1277 Pr SSe So Cr Internal 3 credits

Be interviewed in a formal interview

US1294 Pr So Cr Internal 2 credits

Be assertive in a range of specified situations

US1299 Pr So Cr Internal 4 credits

Select, assess, and read texts to gain knowledge

US2989 Ma Pr SSe Cr Internal 3 credits

Write business correspondence for a workplace

US3488 So SCr Internal 6 credits

Write a short report

US3492 Pr SSo SCr Internal 3 credits

Analyse specified aspect(s) of studied written text(s), supported by evidence

AS91098 (la) UElwra Co Ma Pr Se So Cr External 4 credits

Analyse specified aspect(s) of studied visual or oral text(s), supported by evidence

AS91099 (la) UElwa Co Ma Pr Se So Cr External 4 credits

Analyse significant aspects of unfamiliar written text(s) through close reading, supported by evidence

AS91100 (la) UElwra Co Ma Pr Se So Cr External 4 credits

Produce a selection of crafted and controlled writing

AS91101 (la) UElwa Co Ma Pr Se So Cr Internal 6 credits

Construct and deliver a crafted and controlled oral text

AS91102 (la) Co Pr Se So Cr Internal 3 credits

Create a crafted and controlled visual and verbal text

AS91103 (la) Co Pr Se So Cr Internal 3 credits

Analyse significant connections across texts, supported by evidence

AS91104 (la) Co Pr Se So Cr Internal 4 credits

Use information literacy skills to form developed conclusion(s)

AS91105 (la) UElra Co Ma Pr Se So Cr Internal 4 credits

Form developed personal responses to independently read texts, supported by evidence

AS91106 (la) UElra Co Ma Pr Se So Cr Internal 4 credits

Analyse aspects of visual and/or oral text(s) through close viewing and/or listening, supported by evidence

AS91107 (1a) Cr Internal 3 credits

EN3000

English

NCEA Level 3

EN3000 is the course for all students taking English for level 3. The focus is on skills in 'making and creating meaning', through a range of texts in written, visual and oral forms. At level 3 our skills reflect the sophistication of the text and our audience through critical response.

Within the course, a student can take one of several pathways depending on their goals, interests and skills. Students can alter their path at any time. All standards are available to all students.

Here are the initial options:

- E. (Endorsement) A full NCEA programme with the opportunity to gain endorsement at the Merit or Excellence levels – internal and external standards.
- I. (Internal) A focus on gaining University Entrance with internal standards.
- L. (Literacy – English for work and everyday life) A combination of achievement standards and unit standards that develop communication skills in practical contexts.

The initial choice will determine the first materials students will be sent. Students will then plan their programme in consultation with their teacher. We encourage students, wherever possible, to work in the OTLE environment.

Recommended prior learning: NCEA Level 2 or equivalent in English.

This course is booklet-based – you may download booklets in PDF format from our Online Teaching and Learning Environment (OTLE) or receive printed booklets through the post to complete and return for assessment.

If you are a secondary dual student, you must have access to a computer to download the PDF course booklets.

You may also be sent audio CDs, DVDs, equipment and/or materials through the post.

Write in plain English

US1279 Internal 3 credits

Speak to a known audience in a predictable situation

US1307 Internal 3 credits

Write a report

US3491 Internal 4 credits

Respond critically to specified aspect(s) of studied written text(s), supported by evidence

AS91472 (1a) UElwra External 4 credits

Respond critically to specified aspect(s) of studied visual or oral text(s), supported by evidence

AS91473 (1a) UElwa External 4 credits

Respond critically to significant aspects of unfamiliar written texts through close reading, supported by evidence

AS91474 (1a) UElwra External 4 credits

Produce a selection of fluent and coherent writing which develops, sustains, and structures ideas

AS91475 (1a) UElwa Internal 6 credits

Create and deliver a fluent and coherent oral text which develops, sustains, and structures ideas

AS91476 (1a) Internal 3 credits

Create a fluent and coherent visual text which develops, sustains, and structures ideas using verbal and visual language

AS91477 (1a) Internal 3 credits

Respond critically to significant connections across texts, supported by evidence

AS91478 (1a) Internal 4 credits

Develop an informed understanding of literature and/or language using critical texts

AS91479 (1a) UElra Internal 4 credits

Respond critically to significant aspects of visual and/or oral text(s) through close reading, supported by evidence

AS91480 (1a) Internal 3 credits

LY1500**Literacy for Everyday Life**

NCEA Level 1 (course endorsement not available)

Literacy is the written and spoken language people use in their everyday learning, work and leisure situations. Evidence of literacy can be gained from within any of these learning contexts, including other aspects of the students Learning Programme at Te Kura. This course is only available to young adult and adult students seeking to gain NCEA Level 1 Unit Standard Literacy. Students wanting to enrol in this course will need to be working at least at Curriculum Level 4. On enrolment, students will be required to complete the Adult Literacy Assessment Tool online.

Recommended prior learning: Curriculum Level 4 or 5. Working at Adult Literacy Progression Step 4.

This course is only available in our Online Teaching and Learning Environment (OTLE). It includes a mix of interactive online modules and downloadable booklets in PDF format, so access to a computer and broadband internet is essential. Some assessment activities may be sent to you through the post. Read more on our website at www.tekura.school.nz

Write to communicate ideas for a purpose and audience

US26622 (lu) Internal 4 credits

Read texts with understanding

US26624 (lu) Internal 3 credits

Actively participate in spoken interactions

US26625 (lu) Internal 3 credits

Enterprise Studies

Ngā Akoranga Hinonga

In today's world it's important to be financially capable. Enterprise Studies is about developing students' ability to make informed and effective decisions about the personal use and management of money matters. To achieve this, students need an understanding of their own and others' values. Students will build knowledge and skills in managing money and income, setting goals and planning ahead. Being financially informed will enable them to keep more of the money they earn and do more with the money they spend. Financial literacy empowers them as consumers to make the right choices. It gives students an understanding of how to manage their finances in the real world in order to avoid unnecessary risks and debt.

ES000

Enterprise Studies

Curriculum Levels 4–5

This course aims to help students to become informed about financial matters. It teaches them to manage their earnings, savings, spending, debt and budget. It helps students to set and prioritise their financial goals. They will understand that they have limited resources and, to fulfil their unlimited needs and wants, they need to make wise choices about how to manage their money. This course also focuses on being enterprising by looking at successful entrepreneurs, being innovative, developing business plans, and taking and managing business risks. Throughout this course they will consider financial impacts on their personal life, their whānau/family and the wider community.

Recommended prior learning: No prior learning needed.

This is an online course so access to a computer and broadband internet is essential. Read more on our website at www.tekura.school.nz

French

Te Reo Wīwī

Learning French introduces you not only to a new language but to a culture and society as well. Languages can bring people together and French is widely used for communicating in many parts of the world, including our close Pacific neighbour New Caledonia. People who know French can share in the rich traditions and history of France, a country that continues to fascinate the rest of the world, be it on the rugby field, in the arts or in its culinary reputation. In turn, the ability to speak French can help with travel, business and political interactions around the world.

FR000

Beginners' French

Curriculum Levels 1–5

Language helps to shape people and nations, and this introductory course is designed to help young people learn how to speak and understand French. Basic French vocabulary is developed from being able to introduce yourself, talk about your family and hobbies, and get directions around a French-speaking town. Students will also be introduced to French culture and the various French-speaking countries around the world. The second part of the course revises and extends upon the work done at the beginners' level. Students will learn grammar and further develop general reading, writing and speaking skills. The aim is to equip students with the ability to communicate in everyday situations, and topics include eating and drinking, shopping and a typical day at home. The skill to give and understand directions, as well as describe people, is another major focus of the course, with much of what is taught also providing a valuable insight into general French culture and society.

Recommended prior learning: No prior learning needed.

This is an online course so access to a computer and broadband internet is essential. Some materials may be downloadable booklets in PDF format or sent to you through the post. Read more on our website at www.tekura.school.nz

If you are a secondary dual student, you must have access to a computer to download the PDF course booklets.

For this course you will be required to make and submit audio and/or video recordings, so a microphone – either separate or built into your device – is essential.

FRI000

French

NCEA Level 1 (course endorsement available)

In this NCEA Level 1 course, there is an emphasis on both written and spoken French. It aims to advance on basic listening, speaking, reading and writing skills, and topics are set to reflect common situations students may encounter.

Recommended prior learning: Year 10 French or equivalent or have a French language background.

This course is only available in our Online Teaching and Learning Environment (OTLE). It includes a mix of interactive online modules and downloadable booklets in PDF format, so access to a computer and broadband internet is essential. Some assessment activities may be sent to you through the post. Read more on our website at www.tekura.school.nz

If you are a secondary dual student, you must have access to a computer to download the PDF course booklets.

Demonstrate understanding of a variety of spoken French texts on areas of most immediate relevance

AS90878 Pr Se So Cr External 5 credits

Give a spoken presentation in French that communicates a personal response

AS90879 Pr Internal 4 credits

Demonstrate understanding of a variety of French texts on areas of most immediate relevance

AS90881 Se External 5 credits

Write a variety of text types in French on areas of most immediate relevance

AS90882 Se Cr Internal 5 credits

FR2000**French**

NCEA Level 2 (course endorsement available)

This course will give a deeper appreciation for listening, speaking, reading and writing French and an understanding of life and customs in France and other French-speaking countries. Its focus is on providing a solid knowledge of vocabulary and grammatical structures for communication in a range of everyday situations. Students will gain a greater awareness of French cultural aspects, with topics covered including French-New Zealand links, regional France and France in the new Europe. Furthermore, the course will extend previously learnt linguistic skills and look at themes of health and fitness, fashion and technology.

Recommended prior learning: NCEA Level 1 French or equivalent.

This course is booklet-based – you may download booklets in PDF format from our Online Teaching and Learning Environment (OTLE) or receive printed booklets through the post to complete and return for assessment. If you are a secondary dual student, you must have access to a computer to download the PDF course booklets.

There are some optional supplementary online resources for this course which would be beneficial for your learning. Access to a computer and the internet is essential for these resources.

For this course you will be required to make and submit audio and/or video recordings, so a microphone – either separate or built into your device – is essential.

Demonstrate understanding of a variety of spoken French texts on familiar matters

AS91118 Se Cr External 5 credits

Interact using spoken French to share information and justify ideas and opinions in different situations

AS91119 SSe So Cr Internal 5 credits

Give a spoken presentation in French that communicates information, ideas and opinions

AS91120 Internal 4 credits

Demonstrate understanding of a variety of written and/or visual French text(s) on familiar matters

AS91121 Se External 5 credits

Write a variety of text types in French to convey information, ideas, and opinions in genuine contexts

AS91122 Se Cr Internal 5 credits

FR3000**French**

NCEA Level 3 (course endorsement available)

With a major focus on French literature study and reading, this course consolidates and extends students' linguistic skills in all areas of the French language. The aim is to develop communication skills in a variety of authentic contexts. Students are encouraged to discuss a range of ideas and opinions in French, and relate to cultural aspects of French life. New Zealand Scholarship exams are designed to extend very high achieving level 3 students. Those who wish to enter for the NZ Scholarship exam in this subject must discuss this option with their Te Kura subject teacher.

Recommended prior learning: NCEA Level 2 French or equivalent.

This course is booklet-based – you may download booklets in PDF format from our Online Teaching and Learning Environment (OTLE) or receive printed booklets through the post to complete and return for assessment. If you are a secondary dual student, you must have access to a computer to download the PDF course booklets.

There are some optional supplementary online resources for this course which would be beneficial for your learning. Access to a computer and the internet is essential for these resources.

For this course you will be required to make and submit audio and/or video recordings, so a microphone – either separate or built into your device – is essential.

Demonstrate understanding of a variety of extended spoken French texts

AS91543 External 5 credits

Give a clear spoken presentation in French that communicates a critical response to stimulus material

AS91544 Internal 3 credits

Interact clearly using spoken French to explore and justify varied ideas and perspectives in different situations

AS91545 Internal 6 credits

Demonstrate understanding of a variety of extended written and/or visual French texts

AS91546 External 5 credits

Write a variety of text types in clear French to explore and justify varied ideas and perspectives

AS91547 Internal 5 credits

Gateway/STAR

Ngā Pokenga Mahi/STAR

If you have a chosen career path and want to gain the skills and experience needed to further your goals, Gateway is a tailored programme for you. Structured around work-based learning, it allows students to learn and work while still at school. Full-time students and young adults in a full time course in years 11–13 can apply for Gateway and complete a work placement and learning plan that will give them confidence to go out and achieve their dreams. STAR offers additional learning opportunities in vocational and life skills learning.

GATEWAY

Gateway

Curriculum Level 6

The Gateway programme is a structured, work based learning programme in a vocational pathway of your choice. The Gateway co-ordinator works with each student to develop an individual Gateway learning plan related to the student's particular workplace and industry. Students must arrange and complete a work placement of at least 10 days. Over the duration of the work placement, students will receive on the job training from their workplace supervisor. Gateway applications are welcome from our full-time and young adult students in a full time programme, years 11 to 13 students who are work ready. Places are limited.

Recommended prior learning: No prior learning needed.

This course is booklet-based – you may download booklets in PDF format from our Online Teaching and Learning Environment (OTLE) or receive printed booklets through the post to complete and return for assessment.

STAR

STAR

Curriculum Level 6

STAR courses are short courses at polytechnics or private training providers specifically designed for secondary school students. They give students an introduction to training for a particular trade or skill, and they range in length from a single day to several days in a row, or one day a week for up to two terms.

STAR courses are not a subject, rather they complement the students' studies at Te Kura. However, it is possible to gain unit standards and these credits can be used towards NCEA.

To study unit standard courses, students are typically in years 11–13 and enrolled as a full time student, or a young adult studying three or more subjects. Year 10 students may apply for taster courses and in some exceptional circumstances may be referred by their teacher for a unit standard course. Dual students are not eligible for STAR courses at Te Kura.

Te Kura also arranges some courses just for our students. These include outdoor education (camps in the North and South Islands), Learner Licence training in some centres, or a first aid course at a location near students.

Recommended prior learning: No prior learning needed.

This course is booklet-based – you may download booklets in PDF format from our Online Teaching and Learning Environment (OTLE) or receive printed booklets through the post to complete and return for assessment.

Geography

Te Mātauranga Mātai Matawhenua

Geography is the study of the environment as the home of people. It explores the relationships and connections between people and both natural and cultural environments. Geography investigates the ways in which features are arranged on the earth's surface. It describes and explains the patterns and processes that create them. Students learn to think spatially and use maps, visual images and new technologies to obtain, present and analyse information. Geography students are better able to make sense of a complex and changing world and their place in it. Students will explore real and relevant contemporary contexts, undertake fieldwork investigations and relate them to geographic issues that affect them. By studying geography, students are able to recognise the responsibilities they have in relation to other people, the environment and the long-term sustainability of the planet.

GY1000

Geography

NCEA Level 1 (course endorsement available)

This is an introduction to geography, its basic skills and concepts. Students will learn how the world's natural and cultural environments and people interact through studies of population concepts, sustainability and the effects of extreme natural events. The course teaches students how to draw and interpret maps, as well as how to interpret a variety of information and data. There is a focus on both New Zealand and global issues which will develop research and observation skills and give students the ability to take action and solve problems.

Recommended prior learning: Students should have a reasonable level of literacy.

This course is only available in our Online Teaching and Learning Environment (OTLE). It includes a mix of interactive online modules and downloadable booklets in PDF format, so access to a computer and broadband internet is essential. Some assessment activities may be sent to you through the post. Read more on our website at www.tekura.school.nz

Demonstrate geographic understanding of environments that have been shaped by extreme natural event(s)

AS91007 (la) Pr Se Cr External 4 credits

Demonstrate geographic understanding of population concepts

AS91008 (la) Se So Cr External 4 credits

Demonstrate geographic understanding of the sustainable use of an environment

AS91009 (la) Pr Se Cr Internal 3 credits

Apply concepts and basic geographic skills to demonstrate understanding of a given environment

AS91010 (na) UEna Co Pr Se Cr External 4 credits

Conduct geographic research, with direction

AS91011 (lna) UEna Pr Se Internal 4 credits

Describe aspects of a contemporary New Zealand geographic issue

AS91012 (la) Se So Cr Internal 3 credits

Describe aspects of a geographic topic at a global scale

AS91013 (la) Pr Se Cr Internal 3 credits

GY2000

Geography

NCEA Level 2 (course endorsement available)

At this level, students will study how a large natural environment has evolved over time and created specific landscape features. Students are also asked to consider the differences between developed and less developed countries, and how this affects their people and society. Issues such as access to safe water and the generation of wind power are considered both on a national and international level. Basic geographic skills and techniques will be expanded, and the ability to analyse and interpret an array of data is developed. There is the opportunity to conduct a survey, process the results, reach conclusions and critically evaluate the research findings.

Recommended prior learning: Students should have a reasonable level of literacy.

This course is booklet-based – you may download booklets in PDF format from our Online Teaching and Learning Environment (OTLE) or receive printed booklets through the post to complete and return for assessment.

If you are a secondary dual student, you must have access to a computer to download the PDF course booklets.

There are some optional supplementary online resources for this course which would be beneficial for your learning. Access to a computer and the internet is essential for these resources.

Demonstrate geographic understanding of a large natural environment

AS91240 (la) UElwra Pr SSe External 4 credits

Demonstrate geographic understanding of differences in development

AS91242 (la) UElwra Se So External 4 credits

Apply geography concepts and skills to demonstrate understanding of a given environment

AS91243 (la) Co Pr Se Cr External 4 credits

Conduct geographic research with guidance

AS91244 (lna) UEna Se Cr Internal 5 credits

Explain aspects of a contemporary New Zealand geographic issue

AS91245 (la) Se So Cr Internal 3 credits

Explain aspects of a geographic topic at a global scale

AS91246 (la) Pr Se Internal 3 credits

GY3000

Geography

NCEA Level 3 (course endorsement available)

This geography course involves detailed study of natural processes such as volcanism, and cultural processes such as tourism development. The decision-making processes for obtaining resource planning consent are examined. Advanced research skills are developed through topics of the student's choice that relate to environmental issues. New Zealand Scholarship exams are designed to extend very high achieving level 3 students. Those who wish to enter for the NZ Scholarship exam in this subject must discuss this option with their Te Kura subject teacher.

Recommended prior learning: Students should have a reasonable level of literacy.

This course is booklet-based – you may download booklets in PDF format from our Online Teaching and Learning Environment (OTLE) or receive printed booklets through the post to complete and return for assessment.

If you are a secondary dual student, you must have access to a computer to download the PDF course booklets.

There are some optional supplementary online resources for this course which would be beneficial for your learning. Access to a computer and the internet is essential for these resources.

Demonstrate understanding of how interacting natural processes shape a New Zealand geographic environment

AS91426 (la) UElwra External 4 credits

Demonstrate understanding of how a cultural process shapes geographic environment(s)

AS91427 (la) UElwra External 4 credits

Analyse a significant contemporary event from a geographic perspective

AS91428 (la) UElra Internal 3 credits

Demonstrate understanding of a given environment(s) through selection and application of geographic concepts and skills

AS91429 (la) UElwra External 4 credits

Conduct geographic research with consultation

AS91430 (lna) UEna Internal 5 credits

Analyse aspects of a contemporary geographic issue

AS91431 (la) UElra Internal 3 credits

Analyse aspects of a geographic topic at a global scale

AS91432 (la) Internal 3 credits

German

Te Reo Tiamana

Germany is a country with a long and rich heritage and is at the centre of Europe both geographically and culturally. German is closely related to English and is more similar to English than any other language. With over 100 million German speakers throughout Europe from Austria to Switzerland, it is also a popular language in New Zealand. In turn, there are numerous close links between this country and Germany through trade, tourism and exchanges, making knowledge of the language and people an incredibly useful skill across many areas.

GR000

Beginners' German

Curriculum Levels 1–5

This is a two-part course for beginners (Curriculum Levels 1–3) and advanced beginners (Curriculum Levels 4–5). If students have had prior regular learning of German of about one school year or have some native speaker background, they might consider starting with part two. For all other students, we advise to start with part one.

When enrolling in GR000, students should indicate which part they want to enrol for. In the first part, students are introduced to basic listening, speaking, reading and writing skills using everyday German. They will learn how to greet people, communicate basic information about themselves and others, including looks, hobbies, birthdays, family and their home. They also learn communicating about food, directions and telling the time. German culture is also investigated to give students a broad understanding of the country and customs, behaviour and life in Germany.

In the second part, grammar and all language skills are considered in more depth to increase students' confidence and to build up their language skills. Common and everyday aspects of German language and culture are at the centre. Students will learn how to communicate further about their world, personality, family and interests. Practical topics are also explored such as purchasing goods and communicating about food, festivals and the weather. Communication activities are emphasised throughout.

Recommended prior learning: No prior learning needed.

This is an online course so access to a computer and broadband internet is essential. Some materials may be downloadable booklets in PDF format or sent to you through the post. Read more on our website at www.tekura.school.nz

If you are a secondary dual student, you must have access to a computer to download the PDF course booklets.

For this course you will be required to make and submit audio and/or video recordings, so a microphone – either separate or built into your device – is essential.

GR1000

German

NCEA Level 1 (course endorsement available)

Along with consolidating listening, speaking and reading skills, students will gain an understanding of basic German grammar and writing. There is a focus on communicating and aspects relating to home and family life, as well as a range of leisure activities. It offers a broad insight into life in both Germany and New Zealand, and includes studies of some major German cities and areas.

Recommended prior learning: Students should have completed Year 10 German or equivalent or have a German language background.

This course is only available in our Online Teaching and Learning Environment (OTLE). It includes a mix of interactive online modules and downloadable booklets in PDF format, so access to a computer and broadband internet is essential. Some assessment activities may be sent to you through the post. Read more on our website at www.tekura.school.nz

If you are a secondary dual student, you must have access to a computer to download the PDF course booklets.

For this course you will be required to make and submit audio and/or video recordings, so a microphone – either separate or built into your device – is essential.

Demonstrate understanding of a variety of spoken German texts on areas of most immediate relevance

AS90883 Pr Se So Cr External 5 credits

Give a spoken presentation in German that communicates a personal response

AS90884 Pr Internal 4 credits

Demonstrate understanding of a variety of German texts on areas of most immediate relevance

AS90886 Se External 5 credits

Write a variety of text types in German on areas of most immediate relevance

AS90887 Se Cr Internal 5 credits

GR2000

German

NCEA Level 2 (course endorsement available)

This course consolidates and extends German language skills and further develops an understanding of life in Germany. There is an emphasis on deepening students' ability to communicate both verbally and through writing, and vocabulary and grammar is built on extensively. Topics explored are theme-based and focus on everyday situations. They involve aspects to do with social and school life, along with a look at the environment, youth and future careers. Social and economic relationships between New Zealand and Germany are discussed, alongside a broader investigation into cultural issues where students will learn about Berlin, Germany's multi-cultural population and other German-speaking nations.

Recommended prior learning: NCEA Level 1 German or equivalent.

This course is booklet-based – you may download booklets in PDF format from our Online Teaching and Learning Environment (OTLE) or receive printed booklets through the post to complete and return for assessment.

If you are a secondary dual student, you must have access to a computer to download the PDF course booklets.

There are some optional supplementary online resources for this course which would be beneficial for your learning. Access to a computer and the internet is essential for these resources.

For this course you will be required to make and submit audio and/or video recordings, so a microphone – either separate or built into your device – is essential.

Demonstrate understanding of a variety of spoken German texts on familiar matters

AS91123 Se External 5 credits

Interact using spoken German to share information and justify ideas and opinions in different situations

AS91124 SSe So Cr Internal 5 credits

Give a spoken presentation in German that communicates information, ideas and opinions

AS91125 Internal 4 credits

Demonstrate understanding of a variety of written and/or visual German text(s) on familiar matters

AS91126 Se External 5 credits

Write a variety of text types in German to convey information, ideas, and opinions in genuine contexts

AS91127 Se Cr Internal 5 credits

GR3000

German

NCEA Level 3 (course endorsement available)

This course advances students' linguistic development and German language skills. It challenges them to read, write and speak German in less familiar contexts and with more complex language. As well as vocabulary, grammatical and written abilities will be further broadened. The focus is built around various themes that explore different aspects of German culture, its people and events. From traditional stories to the media and creative arts, students will be challenged to express their thoughts and opinions on these topics in German, as much as possible. New Zealand Scholarship exams are designed to extend very high achieving level 3 students. Those who wish to enter for the NZ Scholarship exam in this subject must discuss this option with their Te Kura subject teacher.

Recommended prior learning: NCEA Level 2 German or equivalent.

This course is booklet-based – you may download booklets in PDF format from our Online Teaching and Learning Environment (OTLE) or receive printed booklets through the post to complete and return for assessment.

If you are a secondary dual student, you must have access to a computer to download the PDF course booklets.

You may also be sent audio CDs, DVDs, equipment and/or materials through the post.

There are some optional supplementary online resources for this course which would be beneficial for your learning. Access to a computer and the internet is essential for these resources.

For this course you will be required to make and submit audio and/or video recordings, so a microphone – either separate or built into your device – is essential.

Demonstrate understanding of a variety of extended spoken German texts

AS91548 External 5 credits

Give a clear spoken presentation in German that communicates a critical response to stimulus material

AS91549 Internal 3 credits

Interact clearly using spoken German to explore and justify varied ideas and perspectives in different situations

AS91550 Internal 6 credits

Demonstrate understanding of a variety of extended written and/or visual German texts

AS91551 External 5 credits

Write a variety of text types in clear German to explore and justify varied ideas and perspectives

AS91552 Internal 5 credits

Health Education

Mātauranga Hauora

In Health Education students consider their well-being, attitudes and values, and work towards promoting the health of their community. Students have the opportunity to participate in a range of tasks, including considering ways to keep themselves safe in a variety of situations, and learning effective ways to communicate to help develop healthy relationships.

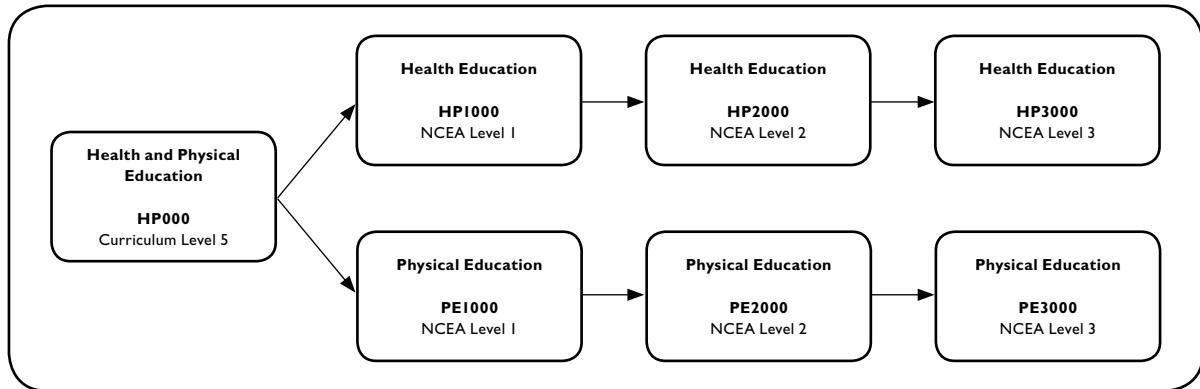

HP000

Health and Physical Education

Curriculum Level 5

In this course students explore health issues such as well-being, nutrition, communication, decision making, problem solving, safety issues around drug use, and understanding gender and sexuality. Students will also study Physical Education topics such as understanding the body, fitness testing, participating in a variety of activities, and being involved in training programmes.

Recommended prior learning: No prior learning needed.

This is an online course so access to a computer and broadband internet is essential. Read more on our website at www.tekura.school.nz

HP1000

Health Education

NCEA Level 1 (course endorsement available)

This course follows on from HP000. In Health Education students explore health issues: the changing states of health, problem solving, understanding sexuality and safety issues around drug use.

The health topics offer 20 credits towards NCEA Level 1. There are four internal standards worth 16 credits and one external standard, worth four credits. Health topics offer 20 Literacy credits.

To gain course endorsement students need to complete 14 credits in Health (this must include the exam).

Recommended prior learning: No prior learning needed.

This course is only available in our Online Teaching and Learning Environment (OTLE). It includes a mix of interactive online modules and downloadable booklets in PDF format, so access to a computer and broadband internet is essential. Some assessment activities may be sent to you through the post. Read more on our website at www.tekura.school.nz

Take action to enhance an aspect of personal well-being
AS90971 (1a) Pr Se So Cr Internal 3 credits

Demonstrate understanding of interpersonal skills used to enhance relationships
AS90973 (1a) Pr Se So Cr Internal 5 credits

Demonstrate understanding of strategies for promoting positive sexuality
AS90974 (1a) So Cr Internal 4 credits

Demonstrate understanding of issues to make health-enhancing decisions in drug-related situations
AS90975 (1a) Pr Se So Cr External 4 credits

Demonstrate understanding of ways in which well-being can change and strategies to support well-being
AS91097 (1a) Pr Se So Cr Internal 4 credits

HP2000**Health Education**

NCEA Level 2 (course endorsement available)

This course follows on from HPI000 and is useful, often essential for students intending to continue with Level 3 Health Education courses. Health Education offers students the opportunity to explore health issues, such as resiliency, understanding sexuality and analysing an adolescent health issue.

The Health Education topics offer 15 credits towards NCEA Level 2. There are two internal standards worth 10 credits and one external standard, worth five credits. These Health Education topics also offer 15 Literacy credits. To gain course endorsement students need to complete 14 credits in Health Education (which includes the exam).

Recommended prior learning: NCEA Level 1 Health Education or equivalent.

This is an online course, so access to a computer and broadband internet is essential. Read more on our website at www.tekura.school.nz

Analyse an adolescent health issue

AS91235 (la) Pr Se So External 5 credits

Evaluate factors that influence people's ability to manage change

AS91236 (la) Pr Se SSo Internal 5 credits

Analyse issues related to sexuality and gender to develop strategies for addressing the issues

AS91239 (la) Pr SSo Internal 5 credits

HP3000**Health Education**

NCEA Level 3 (course endorsement available)

This course follows on from HP2000 and is often essential for students intending to continue with Health Education courses at tertiary institutions. In Health education students have the opportunity to explore health issues, such as a New Zealand and an overseas health issue and analysing an ethical issue.

The Health Education topics offer 14 credits towards NCEA Level 3. There are two internal standards worth nine credits and one external standard, worth five credits. These Health Education topics also offer 14 Literacy credits. To gain course endorsement or entry to a tertiary institution you will need to complete 14 credits in Health Education (which includes an exam).

Recommended prior learning: NCEA Level 2 Health Education or equivalent.

This is an online course, so access to a computer and broadband internet is essential. Read more on our website at www.tekura.school.nz

Analyse a New Zealand health issue

AS91461 (la) UEIra Internal 5 credits

Analyse an international health issue

AS91462 (la) UEIwra External 5 credits

Analyse a contemporary ethical issue in relation to well-being

AS91464 (la) UEIra Internal 4 credits

History

Kōrero Nehe

To understand the past is to understand the present and history gives students an insight into current world problems and an awareness of what it is to be a New Zealander. It explores people and events and how they have influenced the world, both historically and currently. It is not just about presenting the facts but observing and questioning values and attitudes. Students will gain a wider awareness of the world through historical knowledge, while improving their communication and writing skills to enable them to express clear, convincing and well thought out arguments. From ancient civilisations to pop culture, from wars to peace treaties, history is both a fascinating and intellectually stimulating subject.

HS1000

History

NCEA Level 1 (course endorsement available)

Over the last 100 years the world has undergone rapid and significant change, and this course focuses on significant, and at times horrific, historical events throughout the 20th century. The effects of events that are studied can still be seen, and help to provide an understanding of today's international problems. Students will look at the origins of World War II, and why peace did not last in the 1930s. Other conflicts investigated include Palestine and Israel with a focus on the period 1935–2010, and race relations in apartheid-era South Africa. New Zealand's past is also explored through topics on bi-cultural relations between Māori and Pākehā, and the nation's search for security post-World War II. Students will also have the opportunity to undertake their own historical research project on either 'An Enemy of the State' or the 1981 Springbok rugby tour.

Recommended prior learning: Students should have a reasonable level of literacy.

This course is only available in our Online Teaching and Learning Environment (OTLE). It includes a mix of interactive online modules and downloadable booklets in PDF format, so access to a computer and broadband internet is essential. Some assessment activities may be sent to you through the post. Read more on our website at www.tekura.school.nz

Carry out an investigation of an historical event, or place, of significance to New Zealanders

AS91001 (la) Se So Cr Internal 4 credits

Demonstrate understanding of an historical event, or place, of significance to New Zealanders

AS91002 (la) Se So Cr Internal 4 credits

Interpret sources of an historical event of significance to New Zealanders

AS91003 (la) Se So Cr External 4 credits

Demonstrate understanding of different perspectives of people in an historical event of significance to New Zealanders

AS91004 (la) Se So Cr Internal 4 credits

Describe the causes and consequences of an historical event

AS91005 (la) Cr External 4 credits

Describe how a significant historical event affected New Zealand society

AS91006 (la) So Cr External 4 credits

HS2000

History

NCEA Level 2 (course endorsement available)

This course gives an insight into the people and events that have shaped the modern world in the past 150 years. It was a period of significant change with the rise of nationalism, feminism, fascism and communism being just a few of the influential forces that emerged. Students will look into the origins of World War I, the conflict in Vietnam (1945–1975) and how these events affected New Zealand. The changing roles and opportunities for women in New Zealand from 1880–1960 will also be investigated. This course will help develop historical skills such as recognising and examining evidence and presenting information. Students undertake in-depth research work on either the end of World War I and the extent of New Zealand's contribution to the victory, or an aspect of the home front in New Zealand during World War II.

Recommended prior learning: Students should have a reasonable level of literacy.

This course is booklet-based – you may download booklets in PDF format from our Online Teaching and Learning Environment (OTLE) or receive printed booklets through the post to complete and return for assessment.

If you are a secondary dual student, you must have access to a computer to download the PDF course booklets.

There are some optional supplementary online resources for this course which would be beneficial for your learning. Access to a computer and the internet is essential for these resources.

Carry out an inquiry of an historical event or place that is of significance to New Zealanders

AS91229 (la) UElra Se Cr Internal 4 credits

Examine an historical event or place that is of significance to New Zealanders

AS91230 (la) UElra Se Cr Internal 5 credits

Examine sources of an historical event that is of significance to New Zealanders

AS91231 (la) UElwra Cr External 4 credits

Interpret different perspectives of people in an historical event that is of significance to New Zealanders

AS91232 (la) UElra Cr Internal 5 credits

Examine causes and consequences of a significant historical event

AS91233 (la) UElwra Cr External 5 credits

Examine how a significant historical event affected New Zealand society

AS91234 (la) UElwra Cr External 5 credits

HS3000

History England 1558–1660

NCEA Level 3 (course endorsement available)

This course is an alternative to HS3200 History: New Zealand in the 19th century.

There are two main parts to this course.

Part one

For the external standards, students will make an in-depth study of Tudor and Stuart England from 1558 to 1660. It was a period of great upheaval and intrigue, and students will look at how England was governed, issues facing monarchs such as Elizabeth I and the early Stuart kings, and developments during the Civil War and Interregnum. By exploring this time-period, students will learn about early modern English society and its economy, the religious changes that occurred and how these remain relevant even today.

Part two

For the internally assessed standards (AS91434 and AS91437), students will research a 'contested

historical event' that they choose, but which must be approved by their teacher. Events such as: the decision to drop an atomic bomb on Hiroshima, New Zealand's involvement in the loss of Crete to German forces in 1941, the impact of New Zealand women gaining the vote, and whether the trial of Charles I was justified are examples of possible events that students may choose to research.

New Zealand Scholarship exams are designed to extend very high achieving level 3 students. Those who wish to enter for the NZ Scholarship exam in this subject must discuss this option with their Te Kura subject teacher.

Recommended prior learning: Students should have a reasonable level of literacy.

This course is booklet-based – you may download booklets in PDF format from our Online Teaching and Learning Environment (OTLE) or receive printed booklets through the post to complete and return for assessment.

If you are a secondary dual student, you must have access to a computer to download the PDF course booklets.

You may also be sent audio CDs, DVDs, equipment and/or materials through the post.

There are some optional supplementary online resources for this course which would be beneficial for your learning. Access to a computer and the internet is essential for these resources.

Research an historical event or place of significance to New Zealanders, using primary and secondary sources

AS91434 (la) UElra Internal 5 credits

Analyse evidence relating to an historical event of significance to New Zealanders

AS91436 (la) UElwra External 4 credits

Analyse different perspectives of a contested event of significance to New Zealanders

AS91437 (la) UElra Internal 5 credits

Analyse the causes and consequences of a significant historical event

AS91438 (la) UElwra External 6 credits

Analyse a significant historical trend and the force(s) that influenced it

AS91439 (la) UElwra External 6 credits

HS3200

History New Zealand in the 19th century

NCEA Level 3 (course endorsement available)

This course is an alternative to HS3000 History: England 1558–1660. There are two main parts to this course.

Part one

For the external standards and one internal standard (AS91435) students will explore New Zealand in the 19th century: how Māori and Pākehā interacted, the economic and political changes that occurred, and social issues and attitudes that existed. Students will look in detail at some major events in our history from the Treaty of Waitangi to the New Zealand Wars. New Zealand's development from isolation to settler society is also explored.

Part two

For two internally assessed standards (AS91434 and AS91437), students will research a 'contested historical event' that they choose but which must be approved by their teacher. Events such as: the decision to drop an atomic bomb on Hiroshima, New Zealand's involvement in the loss of Crete to German forces in 1941, the impact of New Zealand women gaining the vote, and effects on Māori of large-scale Pākehā migration in the 19th century are examples of possible events that students may choose to research.

New Zealand Scholarship exams are designed to extend very high achieving level 3 students. Those who wish to enter for the NZ Scholarship exam in this subject must discuss this option with their Te Kura subject teacher.

Recommended prior learning: Students should have a reasonable level of literacy.

This course is booklet-based – you may download booklets in PDF format from our Online Teaching and Learning Environment (OTLE) or receive printed booklets through the post to complete and return for assessment.

If you are a secondary dual student, you must have access to a computer to download the PDF course booklets.

You may also be sent audio CDs, DVDs, equipment and/or materials through the post.

There are some optional supplementary online resources for this course which would be beneficial for your learning. Access to a computer and the internet is essential for these resources.

Research an historical event or place of significance to New Zealanders, using primary and secondary sources

AS91434 (la) UElra Internal 5 credits

Analyse an historical event, or place, of significance to New Zealanders

AS91435 (la) UElra Internal 5 credits

Analyse evidence relating to an historical event of significance to New Zealanders

AS91436 (la) UElwra External 4 credits

Analyse different perspectives of a contested event of significance to New Zealanders

AS91437 (la) UElra Internal 5 credits

Analyse the causes and consequences of a significant historical event

AS91438 (la) UElwra External 6 credits

Analyse a significant historical trend and the force(s) that influenced it

AS91439 (la) UElwra External 6 credits

Home Economics

Te Mātauranga Ohaoha Kāinga

From food to family matters, in Home Economics students develop an understanding of the factors that influence the well-being of both themselves and others. With a strong focus on food and nutrition, students evaluate current issues and theories of nutrition and use this knowledge to make informed decisions. Through the processes of selecting, preparing, cooking and serving food, students develop their creativity and personal skills crucial to everyday living. Alongside this, issues relating to family and society are also explored and aim to give students the ability and independence to plan and budget for their future.

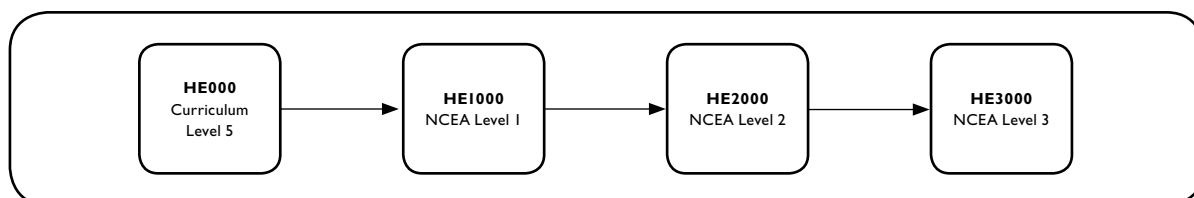

HE000

Home Economics

Curriculum Level 5

In this course students will think critically about food and nutrition. Nutrition is fundamental to developing a sense of well-being to meet the growth and development needs of healthy, confident young people. The course offers opportunities for students to: examine and evaluate their food choices and food related behaviour; challenge opinions and positions, and take action to address food and nutrition related issues; and examine the influence of culture, tradition and media on food choices.

Recommended prior learning: No prior learning needed.

This is an online course so access to a computer and broadband internet is essential. Read more on our website at www.tekura.school.nz

HE1000

Home Economics

NCEA Level 1 (course endorsement available)

Students learn how to use basic nutritional knowledge to make food choices that contribute to health and well-being. This course gives students a broader understanding of their own and others' nutritional demands. Safe food practices and preparation skills are taught and assessed. Societal and cultural influences are considered when looking at eating patterns.

Recommended prior learning: No prior learning needed.

This course is only available in our Online Teaching and Learning Environment (OTLE). It includes a mix of interactive online modules and downloadable booklets in PDF format, so access to a computer and broadband internet is essential. Some assessment activities may be sent to you through the post. Read more on our website at www.tekura.school.nz

Demonstrate knowledge of an individual's nutritional needs

AS90956 Pr Se So Internal 5 credits

Demonstrate understanding of societal influences on an individual's food choices and well-being

AS90957 (1a) Se So Internal 5 credits

Demonstrate understanding of how cultural practices influence eating patterns in New Zealand

AS90958 (1a) Se So Internal 5 credits

Demonstrate knowledge of practices and strategies to address food handling issues

AS90959 (1a) Pr Se So Internal 5 credits

Demonstrate understanding of how packaging information influences an individual's food choices and well-being

AS90961 (1a) Pr Se So External 4 credits

HE2000**Home Economics**

NCEA Level 2 (course endorsement available)

This course has a strong emphasis on taking action to enhance well-being. Students will learn about sustainable health-enhancing change for individuals, communities and society. There is an opportunity for students to develop skills to formulate their own solutions.

Recommended prior learning: NCEA Level 1 Home Economics or equivalent.

This course is booklet-based – you may download booklets in PDF format from our Online Teaching and Learning Environment (OTLE) or receive printed booklets through the post to complete and return for assessment.

If you are a secondary dual student, you must have access to a computer to download the PDF course booklets.

You may also be sent audio CDs, DVDs, equipment and/or materials through the post.

There are some optional supplementary online resources for this course which would be beneficial for your learning. Access to a computer and the internet is essential for these resources.

Exercise informed choice in deciding on a major goods or service purchase

US7127 Cr Internal 2 credits

Describe implications of independent living, including renting and flatting

US12354 Cr Internal 4 credits

Describe household conservation strategies

US12359 Cr Internal 3 credits

Analyse issues related to the provision of food for people with specific food needs

AS91299 (la) Se So Internal 5 credits

Analyse the relationship between well-being, food choices and determinants of health

AS91300 (la) UElwa Se SSo External 4 credits

Evaluate sustainable food related practices

AS91302 (la) Pr Se So Internal 5 credits

Analyse practices to enhance well-being used in care provision in the community

AS91303 (la) Se SSo Internal 5 credits

HE3000**Home Economics**

NCEA Level 3 (course endorsement available)

Students will critically analyse current nutritional issues. There is scope to develop research skills and challenge their own attitudes and values. Knowledge gained from previous studies in Home Economics and Health will be beneficial for students studying at this level.

Recommended prior learning: Students must be able to demonstrate their ability to work at NCEA Level 3.

This course is booklet-based – you may download booklets in PDF format from our Online Teaching and Learning Environment (OTLE) or receive printed booklets through the post to complete and return for assessment.

You may also be sent audio CDs, DVDs, equipment and/or materials through the post.

There are some optional supplementary online resources for this course which would be beneficial for your learning. Access to a computer and the internet is essential for these resources.

Investigate a nutritional issue affecting the well-being of New Zealand society

AS91466 (la) UElra Internal 5 credits

Analyse a food related ethical dilemma for New Zealand society

AS91468 (la) UElra Internal 5 credits

Investigate the influence of multinational food corporations on eating patterns in New Zealand

AS91469 (la) UElra Internal 5 credits

Analyse the influences of food advertising on well-being

AS91471 (la) UElwa External 4 credits

Horticulture

Te Mātauranga Ahuone

Horticulture is the science of caring for plants and gardens. For students with 'green fingers', horticulture gives an introduction to the cultivation of plants, plant propagation, soil care, landscaping and much more. It is both a scientific and practical study of plants, soil and the environment. It provides the knowledge and practical skills to successfully grow plants and crops, both in the home garden and commercially. Horticulture links in with aspects of other subjects such as Science, Geography and Economics. At NCEA Level 3, Horticulture is taught in conjunction with Agriculture.

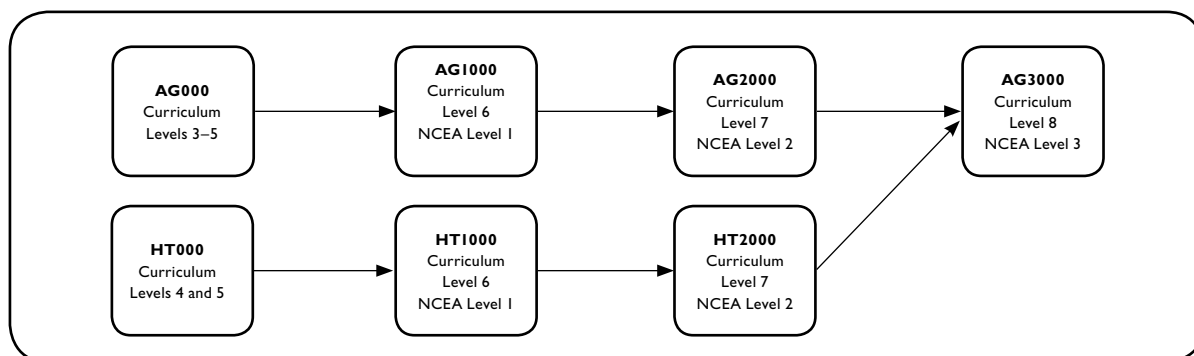

HT000

Introduction to Horticulture

Curriculum Levels 4 and 5

This course is a basic introduction to Horticulture. Students will be encouraged to grow plants to eat and at the same time will develop skills useful for future career opportunities in horticulture. Students will gain knowledge of: the biological make-up of plants, what plants need to survive to produce high yields, the make-up of soil and soil communities, principles of garden design to meet a user's needs, care of the environment for future gardeners, and many other topics of interest.

Recommended prior learning: No prior learning needed.

This is an online course so access to a computer and broadband internet is essential. Read more on our website at www.tekura.school.nz

HT1000

Horticulture

NCEA Level 1 (course endorsement available)

This course covers a variety of general horticultural topics including plant propagation and landscaping. Students will have the opportunity to grow their own vegetable plants. There is a focus on the New Zealand horticultural industry as a whole, and what is involved in producing horticultural products.

Recommended prior learning: Students should have a reasonable level of literacy.

This is a blended course consisting of booklets and web-based units. You may download booklets in PDF format from our Online Teaching and Learning Environment (OTLE) or receive printed booklets through the post to complete and return for assessment.

If you are a secondary dual student, you must have access to a computer to download the PDF course booklets.

You may also be sent audio CDs, DVDs, equipment and/or materials through the post.

There are some optional supplementary online resources for this course which would be beneficial for your learning. Access to a computer and the internet is essential for these resources.

Demonstrate practical skills used in agricultural or horticultural production

AS90157 Pr Internal 4 credits

Demonstrate knowledge of the impact on the environment of primary production management practices

AS90160 (1a) Pr Internal 3 credits

Carry out a practical agricultural or horticultural investigation

AS90918 (na) UEna Pr Internal 4 credits

Demonstrate knowledge of soil management practices
AS90919 (la) Pr External 4 credits

Demonstrate knowledge of the geographic distribution of agricultural and horticultural primary production in New Zealand
AS90920 (la) Pr Internal 3 credits

Design a landscape plan that reflects user requirements
AS90922 Pr Internal 3 credits

Demonstrate knowledge of basic plant propagation techniques
AS90923 (la) Pr Internal 4 credits

Demonstrate knowledge of horticultural plant management practices and related plant physiology
AS90924 (la) Pr External 5 credits

HT2000

Horticulture

NCEA Level 2 (course endorsement available)

This course introduces students to more advanced horticultural concepts. Students will carry out a practical investigation and study a range of horticultural topics including plant propagation, plant management practices and landscaping. During this course, students will learn how to describe and analyse the physical, environmental and biological factors that affect crop growth and development. There are some standards shared with agriculture.

Recommended prior learning: Students should have a reasonable level of literacy.

This course is booklet-based – you may download booklets in PDF format from our Online Teaching and Learning Environment (OTLE) or receive printed booklets through the post to complete and return for assessment.

If you are a secondary dual student, you must have access to a computer to download the PDF course booklets.

You may also be sent audio CDs, DVDs, equipment and/or materials through the post.

There are some optional supplementary online resources for this course which would be beneficial for your learning. Access to a computer and the internet is essential for these resources.

Carry out an extended practical agricultural or horticultural investigation
AS91289 (na) UEna SPr Internal 4 credits

Demonstrate understanding of techniques used to modify physical factors of the environment for NZ plant production
AS91290 (la) SPr External 4 credits

Demonstrate understanding of advanced plant propagation techniques used for commercial production in New Zealand
AS91291 (la) SPr Internal 4 credits

Demonstrate understanding of how management practices influence plant growth and development in NZ commercial production
AS91292 (la) SPr Internal 4 credits

Produce a landscape plan
AS91296 (la) Co SPr Internal 4 credits

Report on the environmental impact of the production of a locally produced primary product
AS91298 (la) SPr Internal 4 credits

AG3000

Agriculture and Horticulture

NCEA Level 3 (course endorsement available)

This combined agriculture and horticulture course will appeal to students with an interest in how primary products are produced and marketed to maximise profits. Based on the production process, students are given an insight into New Zealand's agricultural and horticultural exports, with a particular focus on lamb meat and apple crop production. The course links well with subjects such as biology, geography and economics.

Recommended prior learning: Students should have a reasonable level of literacy.

This course is booklet-based – you may download booklets in PDF format from our Online Teaching and Learning Environment (OTLE) or receive printed booklets through the post to complete and return for assessment.

If you are a secondary dual student, you must have access to a computer to download the PDF course booklets.

You may also be sent audio CDs, DVDs, equipment and/or materials through the post.

There are some optional supplementary online resources for this course which would be beneficial for your learning. Access to a computer and the internet is essential for these resources.

Carry out an investigation into an aspect of a New Zealand primary product or its production

AS91528 (Ina) UEna Internal 4 credits

Research and report on the impact of factors on the profitability of a New Zealand primary product

AS91529 (Ina) UEnra Internal 6 credits

Demonstrate understanding of how market forces affect supply of and demand for New Zealand primary products

AS91530 (Ina) UEnlwa External 5 credits

Demonstrate understanding of how the production process meets market requirements for a New Zealand primary product(s)

AS91531 (Ia) UElwra External 4 credits

Analyse a New Zealand primary production environmental issue

AS91532 (Ia) UElwra External 5 credits

Japanese

Te Reo Hapanihi

Learning Japanese gives students not only the chance to communicate in a language very different from their own, but provides an opportunity to gain an appreciation of a fascinating culture. Along with speaking and listening skills, reading and using the unique kanji writing system can be a rewarding and enjoyable experience. In turn they will find knowledge of Japanese very helpful if they are planning on travelling to Japan or hosting Japanese visitors.

JP000

Beginners' Japanese

Curriculum Levels 1–5

In this introductory course, students will learn how to greet people and introduce themselves, talk about where they live and work, and where they are going. They will also gain the ability to count and tell the time in Japanese, as well as expressing likes and dislikes, and being able to communicate while shopping. They will develop their listening, reading and speaking skills, have the chance to learn to read and write hiragana script, and discover more about Japanese culture.

In the second part of the course, through the theme of 12 Japanese festivals, students will revise and extend their reading, writing, listening and speaking skills. They will also learn to read and write katakana. However, they need to know hiragana before doing this second part of the course. Topics covered include talking about oneself, one's home and family, the weather and sports. Important skills such as asking for directions, ordering food and making apologies are also covered.

Recommended prior learning: No prior learning needed.

This is an online course so access to a computer and broadband internet is essential. Some materials may be downloadable booklets in PDF format or sent to you through the post. Read more on our website at www.tekura.school.nz

If you are a secondary dual student, you must have access to a computer to download the PDF course booklets.

For this course you will be required to make and submit audio and/or video recordings, so a microphone – either separate or built into your device – is essential.

JP1000

Japanese

NCEA Level 1 (course endorsement available)

Students will extend their reading, writing, listening and speaking skills through the experiences of a New Zealand student on a home stay in Japan. Within this theme, students will cover aspects of daily life such as family relationships, travel preparations, hobbies and sports. Other topics include houses and furnishings, senior high school life and travelling by bullet train. Overall, there are approximately 60 kanji characters to learn.

Recommended prior learning: Students should have Year 10 Japanese or equivalent or have a Japanese language background. Ability to read and write hiragana and essential knowledge of katakana an advantage.

This course is only available in our Online Teaching and Learning Environment (OTLE). It includes a mix of interactive online modules and downloadable booklets in PDF format, so access to a computer and broadband internet is essential. Some assessment activities may be sent to you through the post. Read more on our website at www.tekura.school.nz

If you are a secondary dual student, you must have access to a computer to download the PDF course booklets.

For this course you will be required to make and submit audio and/or video recordings, so a microphone – either separate or built into your device – is essential.

Demonstrate understanding of a variety of spoken Japanese texts on areas of most immediate relevance

AS90893 Pr Se So Cr External 5 credits

Give a spoken presentation in Japanese that communicates a personal response

AS90894 Pr Internal 4 credits

Demonstrate understanding of a variety of Japanese texts on areas of most immediate relevance

AS90896 Se External 5 credits

Write a variety of text types in Japanese on areas of most immediate relevance

AS90897 Se Cr Internal 5 credits

JP2000

Japanese

NCEA Level 2 (course endorsement available)

This course introduces about 75 new kanji characters and further extends the ability to read, write, speak and listen in Japanese. Topics covered include: the Japanese school system, land and people, leisure, Japan at work, family life, travel and tourism, eating and drinking.

Recommended prior learning: NCEA Level 1 Japanese course or equivalent.

This course is booklet-based – you may download booklets in PDF format from our Online Teaching and Learning Environment (OTLE) or receive printed booklets through the post to complete and return for assessment.

If you are a secondary dual student, you must have access to a computer to download the PDF course booklets.

There are some optional supplementary online resources for this course which would be beneficial for your learning. Access to a computer and the internet is essential for these resources.

For this course you will be required to make and submit audio and/or video recordings, so a microphone – either separate or built into your device – is essential.

Demonstrate understanding of a variety of spoken Japanese texts on familiar matters

AS91133 Se Cr External 5 credits

Interact using spoken Japanese to share information and justify ideas and opinions in different situations

AS91134 SSe So Cr Internal 5 credits

Give a spoken presentation in Japanese that communicates information, ideas and opinions

AS91135 Internal 4 credits

Demonstrate understanding of a variety of written and/or visual Japanese text(s) on familiar matters

AS91136 Se External 5 credits

Write a variety of text types in Japanese to convey information, ideas, and opinions in genuine contexts

AS91137 Se Cr Internal 5 credits

JP3000

Japanese

NCEA Level 3 (course endorsement available)

This course introduces about 70 new kanji characters and further extends the ability to read, write, speak and listen in Japanese. Topics covered include: Japan at work, leisure, family, travel and tourism, land and people, communication and the media. New Zealand Scholarship exams are designed to extend very high achieving level 3 students. Those who wish to enter for the NZ Scholarship exam in this subject must discuss this option with their Te Kura subject teacher.

Recommended prior learning: NCEA Level 2 Japanese course or equivalent.

This course is booklet-based – you may download booklets in PDF format from our Online Teaching and Learning Environment (OTLE) or receive printed booklets through the post to complete and return for assessment.

If you are a secondary dual student, you must have access to a computer to download the PDF course booklets.

There are some optional supplementary online resources for this course which would be beneficial for your learning. Access to a computer and the internet is essential for these resources.

For this course you will be required to make and submit audio and/or video recordings, so a microphone – either separate or built into your device – is essential.

Demonstrate understanding of a variety of extended spoken Japanese texts

AS91553 External 5 credits

Give a clear spoken presentation in Japanese that communicates a critical response to stimulus material

AS91554 Internal 3 credits

Interact clearly using spoken Japanese to explore and justify varied ideas and perspectives in different situations

AS91555 Internal 6 credits

Demonstrate understanding of a variety of extended written and/or visual Japanese texts

AS91556 External 5 credits

Write a variety of text types in clear Japanese to explore and justify varied ideas and perspectives

AS91557 Internal 5 credits

Latin

Te Reo Rōma Onamata

Latin will provide students with a knowledge and understanding of Roman civilisation and their contribution to the Western world. They will gain insights into the nature of this language which provides the basis for the study of many other foreign languages. Importantly Latin will also help them understand the structure of English and extend their English vocabulary. Please note that Latin is only offered to NCEA Level 1 at Te Kura.

LA000

Beginners' Latin

Curriculum Levels 1–5

This is an introduction to the basics of the Latin language, and the life and history of the Romans in Pompeii, Britain and Alexandria. Students will learn elementary grammar and develop Latin to English translation skills through pronunciation and reading practice. They will continue to explore the life and history of the Romans in both Britain and in Rome, and they will further develop both their grammar and Latin to English translation skills.

Recommended prior learning: No prior learning needed.

This course is booklet-based – you may download booklets in PDF format from our Online Teaching and Learning Environment (OTLE) or receive printed booklets through the post to complete and return for assessment.

If you are a secondary dual student, you must have access to a computer to download the PDF course booklets.

There are some optional supplementary online resources for this course which would be beneficial for your learning. Access to a computer and the internet is essential for these resources.

LAI00

Latin

NCEA Level 1 (course endorsement available)

This course will further extend the skills and knowledge gained in the introductory levels. Over the course, students will translate elementary Latin prose into English, and build an understanding and comprehension of other Latin literature. Aspects of Roman civilisation are also studied, with a focus on their contribution to Western society.

Recommended prior learning: Students should have studied two years of Latin at Year 9 and Year 10 or equivalent.

This course is booklet-based – you may download booklets in PDF format from our Online Teaching and Learning Environment (OTLE) or receive printed booklets through the post to complete and return for assessment.

If you are a secondary dual student, you must have access to a computer to download the PDF course booklets.

There are some optional supplementary online resources for this course which would be beneficial for your learning. Access to a computer and the internet is essential for these resources.

Translate adapted Latin text into English, demonstrating understanding

AS90862 (1a) External 6 credits

Demonstrate understanding of adapted Latin text

AS90863 (1a) External 5 credits

Demonstrate understanding of studied Latin literary text(s)

AS90864 (1a) Internal 6 credits

Present a Roman viewpoint

AS90865 (1a) Internal 4 credits

Demonstrate understanding of Latin in current use

AS90866 (1a) Internal 3 credits

Write short Latin sentences that demonstrate understanding of Latin

AS90867 Internal 3 credits

Legal Studies

Te Akoranga Taha Ture

Legal Studies covers a broad range of topics and aims to provide an understanding of the role of law in society and the basic processes and principles of the New Zealand legal system. Legal Studies explores and evaluates the ability of the legal system to provide just outcomes for all individuals and groups, giving students a better understanding of their legal rights and responsibilities. Students will develop an appreciation of how the legal system impacts on their lives and how they can influence and change it. This subject can lead to a range of possible careers including the legal profession, business, government service or agencies.

LG1000

Legal Studies

NCEA Level 1 (course endorsement not available)

In this Legal Studies course, students explore law as an integral aspect of society and find out how laws are made and applied in everyday life. Students consider why laws are developed and the characteristics of an effective law. Students are able to demonstrate an understanding of the New Zealand court system, the law making process, and how New Zealanders vote for an MMP government. Other major areas of law covered include concepts of democracy and government such as rule of law, separation of powers and civil liberties, and different concepts of justice, such as coercive power and impartiality.

Recommended prior learning: Students should have a reasonable level of literacy.

This course is only available in our Online Teaching and Learning Environment (OTLE). It includes a mix of interactive online modules and downloadable booklets in PDF format, so access to a computer and broadband internet is essential. Some assessment activities may be sent to you through the post. Read more on our website at www.tekura.school.nz

Identify and describe basic employment rights and responsibilities, and sources of information and assistance

US1978 Pr So Internal 3 credits

Demonstrate knowledge of accessing legal assistance

US8548 Pr So Cr Internal 2 credits

Demonstrate understanding of concepts of democracy and government

US27835 Internal 4 credits

Demonstrate understanding of foundational concepts of justice

US27838 Internal 4 credits

Demonstrate understanding of concepts of law

US27841 Internal 4 credits

Demonstrate understanding of litigation and dispute resolution processes in New Zealand

US27844 Internal 4 credits

Demonstrate understanding of law making processes

US27847 Internal 4 credits

Demonstrate understanding of New Zealand's system of government and its formation and operation

US27850 Internal 4 credits

LG2000

Legal Studies

NCEA Level 2 (course endorsement not available)

This Legal Studies course enables students to develop an understanding of the role of law and its relationship to everyday life in New Zealand. Students will explore concepts of law such as crime, negligence and contract. They study litigation and dispute resolution processes used in New Zealand, how laws are reformed and different voting systems such as MMP and FPP. Other major areas of law covered include concepts of democracy and government such as rule of law, separation of powers and liberal democracy, and different concepts of justice, such as restorative justice and marae justice.

Recommended prior learning: Students should have a reasonable level of literacy.

This course is booklet-based – you may download booklets in PDF format from our Online Teaching and Learning Environment (OTLE) or receive printed booklets through the post to complete and return for assessment.

If you are a secondary dual student, you must have access to a computer to download the PDF course booklets.

There are some optional supplementary online resources for this course which would be beneficial for your learning. Access to a computer and the internet is essential for these resources.

Describe employment relationships and agreements
US1979 Cr Internal 3 credits

Describe factors contributing to, and consequences of, crime
US8545 SSo Internal 3 credits

Describe the application of New Zealand law to marriage, civil union, and de-facto relationships
US8551 So Internal 3 credits

Describe legal consequences and protections relating to domestic violence and child abuse
US8552 SSo Internal 3 credits

Describe the objectives and application of consumer law
US8555 So Cr Internal 3 credits

Describe the legal rights and personal responsibilities of secondary school students
US10337 So Internal 3 credits

Explain concepts of democracy and government in a New Zealand context
US27836 So Internal 4 credits

Explain concepts of justice
US27839 So Internal 4 credits

Explain concepts of law
US27842 So Internal 4 credits

Explain litigation and dispute resolution processes
US27845 So Internal 4 credits

Explain a law making process
US27848 SSo Internal 4 credits

Explain systems of government and their formation and operation in a New Zealand context
US27851 So Internal 4 credits

LG3000

Legal Studies

NCEA Level 3 (course endorsement not available)

Students at this level will be able to evaluate concepts and principles, and systems and processes of the New Zealand and other legal systems. They will explore the application of a concept of law such as crime or natural justice to real situations. Students study formal means of challenging state power, such as the Ombudsman used in New Zealand, and evaluate a law making process associated with a major issue such as film production in New Zealand. Other major areas of law covered include concepts of democracy and government and different concepts of justice,

evaluated in relation to specific situations such as significant events or particular legislation. NCEA Level 3 Legal Studies is not on the NZQA approved subject list for University Entrance. However the unit standards gained in LG3000 can count towards the other 18 credits required for NCEA Level 3, which is a requirement for University Entrance.

Recommended prior learning: Students should have a reasonable level of literacy.

This course is booklet-based – you may download booklets in PDF format from our Online Teaching and Learning Environment (OTLE) or receive printed booklets through the post to complete and return for assessment.

If you are a secondary dual student, you must have access to a computer to download the PDF course booklets.

There are some optional supplementary online resources for this course which would be beneficial for your learning. Access to a computer and the internet is essential for these resources.

Demonstrate knowledge of the development of the New Zealand legal system
US10347 Internal 5 credits

Evaluate a concept of democracy and government in relation to restraint on state power
US27837 Internal 4 credits

Evaluate a concept of justice in relation to a specific situation
US27840 Internal 4 credits

Evaluate a concept of law in relation to a specific situation
US27843 Internal 4 credits

Evaluate litigation and dispute resolution processes in relation to challenging state power
US27846 Internal 4 credits

Evaluate a law making process in relation to a significant legal issue
US27849 Internal 4 credits

Evaluate systems of government and their formation
US27852 Internal 4 credits

Life Skills

Ngā pūkenga whai oranga

This Life Skills course provides opportunities to develop skills for everyday living and can lead into further study in Pathways education. The learning materials and experiences are ideal for students in years 9 and 10.

LS100**Life Skills**

Curriculum Levels 2 and 3

This course focuses on developing knowledge and skills to assist with everyday living. The units of work include preparation for employment, preparing a CV, job interview skills, goal setting, budgeting, shopping, time management, filling in forms, interpersonal and social skills, accessing information in maps and timetables, using public transport, computing and communication technology.

Recommended prior learning: No prior learning needed.

This course is booklet-based – you will receive printed booklets through the post to complete and return for assessment.

Mathematics

Te Mātauranga Pāngarau

This subject is more than just numbers! Mathematics is the exploration and use of patterns and relationships in quantities, space and time. Statistics focuses on patterns and relationships in data. Students will be equipped with powerful communication and problem solving tools for investigating, interpreting and making sense of the world. Using symbols, graphs and diagrams to investigate patterns and relationships, students model real-life and hypothetical situations in a range of contexts – social, cultural, scientific, technological, health, environmental and economic. Mathematics develops an ability to think creatively, critically, strategically and logically. Students learn to structure, organise, process and communicate information.

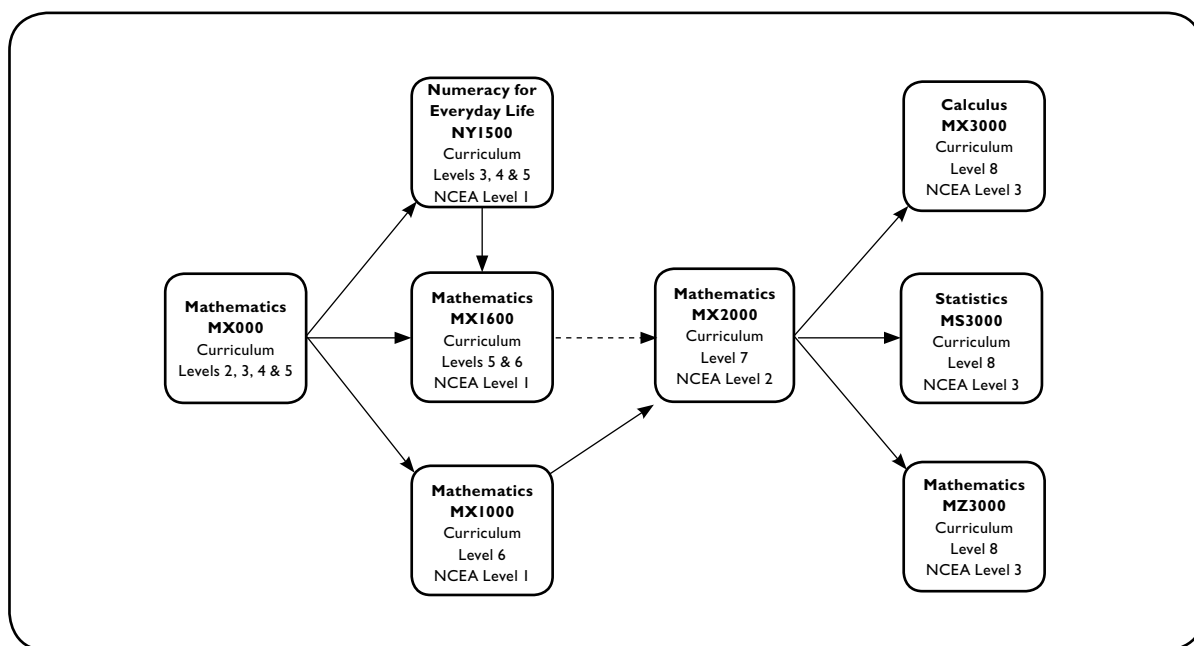

MX000

General Mathematics

Curriculum Levels 2–5

Individualised courses are designed to give students a strong basis in the fundamentals of mathematics and its processes, and to build confidence in the development and application of basic skills.

Each curriculum level develops the concepts of statistics, probability, geometry, measurement, number and algebra, applying these to practical problems. In the lower curriculum levels, the focus is on core skills of numeracy, measurement, money, reading tables and graphs, using a calculator, basic arithmetic and shape patterns. After mastering these, students progress towards an understanding of whole numbers, decimals, fractions, percentages and integers, and learn the skills needed to construct and interpret statistical graphs.

Other topics covered include perimeter, area and volume, investigating mass, capacity, time and temperature, ratios, mean and range, exploring patterns, equations and locating position.

Curriculum level 5 is the foundation for NCEA Level 1. Concepts are connected in new topics such as trigonometry. There is even greater emphasis on solving realistic problems using a variety of approaches, with clear and concise communication of thinking.

Recommended prior learning: No prior learning needed.

This is an online course so access to a computer and broadband internet is essential. Some materials may be downloadable booklets in PDF format or sent to you through the post. Read more on our website at www.tekura.school.nz

MXI000**Mathematics and Statistics**

NCEA Level I (course endorsement available)

This is a level I course covering all areas of mathematics and statistics at curriculum level 6. Students will learn the skills needed for mathematical processes with a focus on algebra, angle geometry and trigonometry, and probability. Teaching is also available in number, measurement, statistics, constructions and transformations. Students can select from the achievement standards to a maximum total of 24 credits.

Recommended prior learning: Students should have studied mathematics at Curriculum Level 5 or equivalent.

This course is only available in our Online Teaching and Learning Environment (OTLE). It includes a mix of interactive online modules and downloadable booklets in PDF format, so access to a computer and broadband internet is essential. Some assessment activities may be sent to you through the post. Read more on our website at www.tekura.school.nz

Apply numeric reasoning in solving problems

AS91026 (na) UEna Co Ma Pr Se So Cr Internal 4 credits

Apply algebraic procedures in solving problems

AS91027 (na) UEna Co Ma Pr Se So Cr External 4 credits

Investigate relationships between tables, equations and graphs

AS91028 (na) UEna Co Ma Pr Se Cr External 4 credits

Apply linear algebra in solving problems

AS91029 (na) UEna Co Ma Pr Se So Cr Internal 3 credits

Apply measurement in solving problems

AS91030 (na) UEna Co Ma Pr Se So Cr Internal 3 credits

Apply geometric reasoning in solving problems

AS91031 (na) UEna Co Ma Pr Se Cr External 4 credits

Apply right-angled triangles in solving measurement problems

AS91032 (na) UEna Co Ma Pr Se Cr Internal 3 credits

Apply knowledge of geometric representations in solving problems

AS91033 (na) UEna Co Ma Pr Cr Internal 3 credits

Apply transformation geometry in solving problems

AS91034 (na) UEna Co Ma Pr Se Cr Internal 2 credits

Investigate a given multivariate data set using the statistical enquiry cycle

AS91035 (Ina) UEna Co Ma Pr Se So Cr Internal 4 credits

Investigate bivariate numerical data using the statistical enquiry cycle

AS91036 (Ina) UEna Pr Se So Cr Internal 3 credits

Demonstrate understanding of chance and data

AS91037 (na) UEna Pr Se So Cr External 4 credits

Investigate a situation involving elements of chance

AS91038 (Ina) UEna Pr Se Cr Internal 3 credits

NYI500**Numeracy for Everyday Life**

NCEA Level I (course endorsement not available)

This course is for students seeking to gain the three level I numeracy unit standards in the Work and Study Skills domain. Eligible students will be young adults or adults. The content covers number, measurement and statistics. Students gaining the minimum numeracy requirements for level I can transition into MXI600 or MXI000.

Recommended prior learning: No prior learning needed.

This course is booklet-based – you may download booklets in PDF format from our Online Teaching and Learning Environment (OTLE) or receive printed booklets through the post to complete and return for assessment.

If you are a secondary dual student, you must have access to a computer to download the PDF course booklets.

You may also be sent audio CDs, DVDs, equipment and/or materials through the post.

There are some optional supplementary online resources for this course which would be beneficial for your learning. Access to a computer and the internet is essential for these resources.

Use number to solve problems

US26623 (nu) UEnu Internal 4 credits

Interpret statistical information for a purpose

US26626 (nu) UEnu Internal 3 credits

Use measurement to solve problems

US26627 (nu) UEnu Internal 3 credits

MXI600**Mathematics and Statistics**

NCEA Level 1 (course endorsement not available)

This is a level 1 course covering number, measurement, trigonometry, geometry, statistics and probability at curriculum level 6. All achievement standards in this course are internally assessed. Progression to level 2 for students completing this course will be on a case by case basis. Students can select from the achievement standards to a maximum total of 24 credits.

Recommended prior learning: Students should have studied mathematics at Curriculum Level 4 or equivalent.

This course is only available in our Online Teaching and Learning Environment (OTLE). It includes a mix of interactive online modules and downloadable booklets in PDF format, so access to a computer and broadband internet is essential. Some assessment activities may be sent to you through the post. Read more on our website at www.tekura.school.nz

Apply numeric reasoning in solving problems

AS91026 (na) UEna Co Ma Pr Se So Cr Internal 4 credits

Apply measurement in solving problems

AS91030 (na) UEna Co Ma Pr Se So Cr Internal 3 credits

Apply right-angled triangles in solving measurement problems

AS91032 (na) UEna Co Ma Pr Se Cr Internal 3 credits

Apply knowledge of geometric representations in solving problems

AS91033 (na) UEna Co Ma Pr Cr Internal 3 credits

Apply transformation geometry in solving problems

AS91034 (na) UEna Co Ma Pr Se Cr Internal 2 credits

Investigate a given multivariate data set using the statistical enquiry cycle

AS91035 (Ina) UEna Co Ma Pr Se So Cr Internal 4 credits

Investigate bivariate numerical data using the statistical enquiry cycle

AS91036 (Ina) UEna Pr Se So Cr Internal 3 credits

Investigate a situation involving elements of chance

AS91038 (Ina) UEna Pr Se Cr Internal 3 credits

MX2000**Mathematics and Statistics**

NCEA Level 2 (course endorsement available)

This course covers all major areas of mathematics and statistics at curriculum level 7. Students will learn skills needed for mathematical processes with a focus on algebra, geometry, measurement, probability and statistics. Students can select from the achievement standards to a maximum total of 24 credits.

Recommended prior learning: NCEA Level 1 Maths or equivalent.

This course is booklet-based – you may download booklets in PDF format from our Online Teaching and Learning Environment (OTLE) or receive printed booklets through the post to complete and return for assessment.

If you are a secondary dual student, you must have access to a computer to download the PDF course booklets.

You may also be sent audio CDs, DVDs, equipment and/or materials through the post.

There are some optional supplementary online resources for this course which would be beneficial for your learning. Access to a computer and the internet is essential for these resources.

Apply co-ordinate geometry methods in solving problems

AS91256 (na) UEna Co Ma Se Cr Internal 2 credits

Apply graphical methods in solving problems

AS91257 (na) UEna Co Ma Pr Se Cr Internal 4 credits

Apply sequences and series in solving problems

AS91258 (na) UEna Co Ma Pr So Cr Internal 2 credits

Apply trigonometric relationships in solving problems

AS91259 (na) UEna Co Ma Cr Internal 3 credits

Apply network methods in solving problems

AS91260 (na) UEna Co Ma Pr Se So Cr Internal 2 credits

Apply algebraic methods in solving problems

AS91261 (na) UEna Co Ma Pr Cr External 4 credits

Apply calculus methods in solving problems

AS91262 (na) UEna Co Ma Pr Cr External 5 credits

Design a questionnaire

AS91263 (Ina) UEna Pr Se So Cr Internal 3 credits

Use statistical methods to make an inference

AS91264 (Ina) UEna Pr Se So Cr Internal 4 credits

Conduct an experiment to investigate a situation using statistical methods

AS91265 (Ina) UEna Co Ma Pr Se So Cr Internal 3 credits

Evaluate a statistically based report

AS91266 (Ina) UEnra Co Ma Pr Se Cr Internal 2 credits

Apply probability methods in solving problems

AS91267 (Ina) UEna Pr Se So Cr External 4 credits

Investigate a situation involving elements of chance using a simulation

AS91268 (Ina) UEna Pr So Cr Internal 2 credits

Apply systems of equations in solving problems

AS91269 (na) UEna Co Ma Cr Internal 2 credits

MX3000

Calculus

NCEA Level 3 (course endorsement available)

This course is designed to prepare the student for the study of mathematics, pure and applied sciences or engineering at a tertiary level. The focus is on calculus, with students encountering algebra and trigonometry topics, as well as the manipulation of real and complex numbers, and geometry and conic sections. Students can select from the achievement standards to a maximum total of 24 credits.

Recommended prior learning: NCEA Level 2 Maths or equivalent.

This course is booklet-based – you may download booklets in PDF format from our Online Teaching and Learning Environment (OTLE) or receive printed booklets through the post to complete and return for assessment.

If you are a secondary dual student, you must have access to a computer to download the PDF course booklets.

You may also be sent audio CDs, DVDs, equipment and/or materials through the post.

There are some optional supplementary online resources for this course which would be beneficial for your learning. Access to a computer and the internet is essential for these resources.

Apply the geometry of conic sections in solving problems

AS91573 (na) UEna Internal 3 credits

Apply linear programming methods in solving problems

AS91574 (na) UEna Internal 3 credits

Apply trigonometric methods in solving problems

AS91575 (na) UEna Internal 4 credits

Use critical path analysis in solving problems

AS91576 (na) UEna Internal 2 credits

Apply the algebra of complex numbers in solving problems

AS91577 (na) UEna External 5 credits

Apply differentiation methods in solving problems

AS91578 (na) UEna External 6 credits

Apply integration methods in solving problems

AS91579 (na) UEna External 6 credits

Apply systems of simultaneous equations in solving problems

AS91587 (na) UEna Internal 3 credits

MS3000

Statistics

NCEA Level 3 (course endorsement available)

Students interested in the analysis and interpretation of quantitative data will find this course useful. With a focus on statistics, it explores probability, sampling and statistical inference, along with the analysis of time series and bivariate data. Writing reports that justify the findings of an analysis is part of this course. This course is appropriate as a foundation in statistical exploration to support any area of study at tertiary level, especially the biological sciences, social sciences or commerce. Access to a spreadsheet such as Excel, and a graphing or CAS calculator is essential. Students can select from the following achievement standards to a maximum total of 24 credits.

Recommended prior learning: NCEA Level 2 Maths or equivalent.

This course is booklet-based – you may download booklets in PDF format from our Online Teaching and Learning Environment (OTLE) or receive printed booklets through the post to complete and return for assessment.

If you are a secondary dual student, you must have access to a computer to download the PDF course booklets.

You may also be sent audio CDs, DVDs, equipment and/or materials through the post.

There are some optional supplementary online resources for this course which would be beneficial for your learning. Access to a computer and the internet is essential for these resources.

Investigate time series data

AS91580 (Ina) UEna Internal 4 credits

Investigate bivariate measurement data

AS91581 (Ina) UEna Internal 4 credits

Use statistical methods to make a formal inference

AS91582 (Ina) UEna Internal 4 credits

Conduct an experiment to investigate a situation using experimental design principles

AS91583 (Ina) UEna Internal 4 credits

Evaluate statistically based reports

AS91584 (Ina) UEnlwa External 4 credits

Apply probability concepts in solving problems

AS91585 (na) UEna External 4 credits

Apply probability distributions in solving problems

AS91586 (na) UEna External 4 credits

MZ3000

Mathematics

NCEA Level 3 (course endorsement available)

This course takes a number of achievement standards from the Calculus and Statistics courses and creates a blended course called Mathematics. The focus of this course is on linear programming, networks, calculus and trigonometry, with students also having an opportunity to develop statistical and probabilistic skills encountered in time series, statistical reports, bivariate analysis and statistical inference. Students can select from the following achievement standards to a maximum total of 24 credits.

Recommended prior learning: NCEA Level 2 Maths or equivalent.

This course is booklet-based – you may download booklets in PDF format from our Online Teaching and Learning Environment (OTLE) or receive printed booklets through the post to complete and return for assessment.

If you are a secondary dual student, you must have access to a computer to download the PDF course booklets.

You may also be sent audio CDs, DVDs, equipment and/or materials through the post.

There are some optional supplementary online resources for this course which would be beneficial for your learning. Access to a computer and the internet is essential for these resources.

Apply linear programming methods in solving problems

AS91574 (na) UEna Internal 3 credits

Apply trigonometric methods in solving problems

AS91575 (na) UEna Internal 4 credits

Use critical path analysis in solving problems

AS91576 (na) UEna Internal 2 credits

Apply differentiation methods in solving problems

AS91578 (na) UEna External 6 credits

Investigate time series data

AS91580 (Ina) UEna Internal 4 credits

Investigate bivariate measurement data

AS91581 (Ina) UEna Internal 4 credits

Use statistical methods to make a formal inference

AS91582 (Ina) UEna Internal 4 credits

Evaluate statistically based reports

AS91584 (Ina) UEnlwa External 4 credits

Apply systems of simultaneous equations in solving problems

AS91587 (na) UEna Internal 3 credits

Media Studies

Te Akoranga Pāpāho

Students will learn various journalism, close reading and analytical skills in Media Studies. Students can create their own media product through studies in representation, genre, and narrative. Media Studies enables students to be more media aware and media 'savvy' – vital tools in today's society.

MDI000

Media Studies

NCEA Level 1 (course endorsement available)

Level 1 Media Studies looks at all aspects of the media including: film, television, radio, print, social networking and the web. Students will work closely with their teacher to work out an appropriate programme based on their strengths, interests and literacy.

Recommended prior learning: Students will need to have strong literacy and computer skills and have worked successfully in literacy rich subjects at NCEA Level 1.

This is an online course, so access to a computer and broadband internet is essential. Read more on our website at www.tekura.school.nz

Demonstrate understanding of how individuals interact with the media

AS90989 (1na) UEna Se Cr Internal 3 credits

Demonstrate understanding of selected elements of media text(s)

AS90990 (1a) Cr Internal 3 credits

Demonstrate understanding of characteristics of a media genre

AS90992 (1a) Se Cr External 4 credits

Produce a design and plan for a media product using a specified range of conventions

AS90993 Se Cr Internal 3 credits

Complete a media product from a design and plan using a specified range of conventions

AS90994 Cr Internal 6 credits

Write media texts for a specific target audience

AS90996 (1a) Se Cr Internal 3 credits

MD2000

Media Studies

NCEA Level 2 (course endorsement available)

Level 2 Media Studies looks at many aspects of the media including: film, print, social networking and the web. Students will work closely with their teacher to work out an appropriate programme based on their strengths, interests and literacy.

Recommended prior learning: Students will need to have strong literacy and computer skills and have worked successfully in literacy rich subjects at NCEA Level 1.

This is an online course, so access to a computer and broadband internet is essential. Read more on our website at www.tekura.school.nz

Demonstrate understanding of the relationship between a media product and its audience

AS91248 (1a) UElwra Se SCr External 3 credits

Demonstrate understanding of narrative in media texts

AS91249 (1a) SCr Internal 4 credits

Demonstrate understanding of representation in the media

AS91250 (1a) SCr Internal 3 credits

Demonstrate understanding of an aspect of a media genre

AS91251 (1a) UElwra SCr External 4 credits

Produce a design and plan for a developed media product using a range of conventions

AS91252 (1a) SCr Internal 4 credits

Complete a developed media product from a design and plan using a range of conventions

AS91253 (1a) SCr Internal 6 credits

Write developed media text for a specific target audience

AS91255 (1a) UElwa Se SCr Internal 3 credits

MD3000**Media Studies**

NCEA Level 3 (course endorsement available)

Level 3 Media Studies looks at many aspects of the media including: film, television, print, social networking and the web. Students will work closely with their teacher to work out an appropriate programme based on their strengths, interests and literacy.

Recommended prior learning: Students will need to have strong literacy and computer skills and have worked successfully in literacy rich subjects at NCEA Level 2.

This is an online course, so access to a computer and broadband internet is essential. Read more on our website at www.tekura.school.nz

Demonstrate understanding of the meaning of a media text through different readings

AS91491 (la) Internal 3 credits

Demonstrate understanding of the media representation of an aspect of New Zealand culture or society

AS91492 (la) Internal 3 credits

Demonstrate understanding of a relationship between a media genre and society

AS91493 (la) UElwra External 4 credits

Produce a design for a media product that meets the requirements of a brief

AS91494 (la) Internal 4 credits

Produce a media product to meet the requirements of a brief

AS91495 (la) Internal 6 credits

Write a media text to meet the requirements of a brief

AS91497 (la) UElwa Internal 3 credits

Music

Te Mātauranga Pūoru

From classical operas to pop hits, the study of music can enhance personal music tastes. With so many diverse styles of music, there are endless options to explore and students will have the opportunity to discover a wide variety of music. In turn, music is a fundamental aspect of any culture and a greater understanding of it can provide a unique insight into a society. Along with cultural knowledge, students have the chance to develop their own practical music skills which can further enhance not only their creative and critical abilities, but the enjoyment that comes from listening to music.

MC000

General Music

Curriculum Levels 3–5

This course helps students nurture a lifelong enjoyment of and participation in music. It offers opportunities in a wide range of different styles and types of music activities and those intending to do music at NCEA levels can develop appropriate skills and knowledge. Students are strongly encouraged to have their own instrument (voice is an instrument) and have access to a music mentor within their own community.

Recommended prior learning: No prior learning needed.

This is an online course so access to a computer and broadband internet is essential. Read more on our website at www.tekura.school.nz

activities may be sent to you through the post. Read more on our website at www.tekura.school.nz

Demonstrate and apply introductory knowledge of music technology equipment and techniques

US27656 Cr Internal 4 credits

Perform dance sequences

AS90002 Cr Internal 6 credits

Demonstrate ensemble skills in a dance

AS90859 Cr Internal 4 credits

Perform two pieces of music as a featured soloist

AS91090 Cr Internal 6 credits

Demonstrate ensemble skills through performing a piece of music as a member of a group

AS91091 Cr Internal 4 credits

Compose two original pieces of music

AS91092 Cr Internal 6 credits

Demonstrate aural and theoretical skills through transcription

AS91093 Cr External 4 credits

Demonstrate knowledge of conventions used in music scores

AS91094 (la) Cr External 4 credits

Demonstrate knowledge of two music works from contrasting contexts

AS91095 (la) Cr Internal 6 credits

MP1000

Music

NCEA Level 1 (course endorsement available)

This course builds skills in solo and group performance on an instrument or with voice. It also provides study of composition, music knowledge, aural perception, score reading and music technology (only in consultation with the senior teacher). All students need their own instrument. As a way of acknowledging students' strengths in broader performing arts disciplines, some level 1 dance standards are also offered within this course.

Recommended prior learning: Students should have two or more years of music learning. To undertake the dance standards, students should have two or more years, experience in dance or Māori performing arts or both.

This course is only available in our Online Teaching and Learning Environment (OTLE). It includes a mix of interactive online modules and downloadable booklets in PDF format, so access to a computer and broadband internet is essential. Some assessment

MP2000

Music

NCEA Level 2 (course endorsement available)

This course continues to build skills in solo and group performance on an instrument or with voice. It also provides further study of composition, music knowledge, score reading and music technology (only in consultation with the senior teacher). All students need their own instrument. As a way of acknowledging students' strengths in broader performing arts disciplines, some level 2 dance standards are also offered within this course.

Pathways Education

Te Mātauranga Rapuara

Pathways Education provides learning opportunities to develop the foundation skills required to move successfully between school and work, be prepared for further education, and for moving into paid employment or working in the voluntary sector.

PW1001

Getting ready for work

NCEA Level I

Pathways Education helps you develop skills and knowledge for an employment environment. The course is made up of four modules. Students start on the first module PW1001 with Starting Out and then choose any of the other modules.

Please note PW1003 will be easier for students who have or have had a work placement. This can be voluntary work, a part time job, work experience or a Gateway placement. PW1004 Introduction to Automotive Skills is a restricted course and you will need to apply to your Pathways teacher.

Recommended prior learning: Students should have a reasonable level of literacy.

This course is only available in our Online Teaching and Learning Environment (OTLE). It includes a mix of interactive online modules and downloadable booklets in PDF format, so access to a computer and broadband internet is essential. Some assessment activities may be sent to you through the post. Read more on our website at www.tekura.school.nz

Describe requirements and expectations faced by employees within the workplace

US4248 Pr Internal 3 credits

Demonstrate knowledge of workplace health and safety requirements

US497 Co Ma Pr Se So Cr Internal 3 credits

Produce a CV (curriculum vitae)

US504 Pr So Internal 2 credits

Identify and describe basic employment rights and responsibilities, and sources of information and assistance

US1978 Pr So Internal 3 credits

Describe care and timeliness as an employee

US4249 Co Pr Internal 3 credits

PW1002

Self-management skills

NCEA Level I

Pathways Education helps you develop skills and knowledge for an employment environment. The course is made up of four modules. Students start on the first module PW1001 with Starting Out and then choose any of the other modules.

Please note PW1003 will be easier for students who have or have had a work placement. This can be voluntary work, a part time job, work experience or a Gateway placement. PW1004 Introduction to Automotive Skills is a restricted course and you will need to apply to your Pathways teacher.

Recommended prior learning: Students should have a reasonable level of literacy.

This course is only available in our Online Teaching and Learning Environment (OTLE). It includes a mix of interactive online modules and downloadable booklets in PDF format, so access to a computer and broadband internet is essential. Some assessment activities may be sent to you through the post. Read more on our website at www.tekura.school.nz

Describe community services

US526 So Internal 2 credits

Manage personal wellness

US496 So,Cr Internal 3 credits

Demonstrate knowledge of anger and options for dealing with anger issues

US12348 Pr So Cr Internal 2 credits

Produce a balanced budget to manage personal finances

US24709 Pr So Cr Internal 3 credits

Interpret financial documents and verify accuracy of financial documents for personal financial management

US24705 So Cr Internal 2 credits

PWI003**Work skills**

NCEA Level I

Pathways Education helps you develop skills and knowledge for an employment environment. The course is made up of four modules. Students start on the first module PWI001 with Starting Out and then choose any of the other modules.

Please note PWI003 will be easier for students who have or have had a work placement. This can be voluntary work, a part time job, work experience or a Gateway placement. PWI004 Introduction to Automotive Skills is a restricted course and you will need to apply to your Pathways teacher.

Recommended prior learning: Students should have a reasonable level of literacy.

This course is only available in our Online Teaching and Learning Environment (OTLE). It includes a mix of interactive online modules and downloadable booklets in PDF format, so access to a computer and broadband internet is essential. Some assessment activities may be sent to you through the post. Read more on our website at www.tekura.school.nz

Be interviewed in an informal one-to-one, face-to-face interview

US1293 Ma Pr So Cr Internal 2 credits

Fill in a form

US3483 Pr So Cr Internal 2 credits

Describe discrimination under the Human Rights Act 1993 and describe ways of responding to it

US542 Pr So Internal 2 credits

Participate and communicate in a team or group to complete a routine task

US3503 Pr So Cr Internal 2 credits

Perform income-related calculations for personal financial management

US24697 So Cr Internal 1 credits

Perform calculations for the workplace

US64 Ma Pr Se So Internal 2 credits

PWI004**Introduction to automotive**

NCEA Level I

Pathways Education helps you develop skills and knowledge for an employment environment. The course is made up of four modules. Students start on the first module PWI001 with Starting Out and then choose any of the other modules.

Please note PWI003 will be easier for students who have or have had a work placement. This can be voluntary work, a part time job, work experience or a Gateway placement. PWI004 Introduction to Automotive Skills is a restricted course and you will need to apply to your Pathways teacher.

Recommended prior learning: Students should have a reasonable level of literacy.

This course is only available in our Online Teaching and Learning Environment (OTLE). It includes a mix of interactive online modules and downloadable booklets in PDF format, so access to a computer and broadband internet is essential. Some assessment activities may be sent to you through the post. Read more on our website at www.tekura.school.nz

Demonstrate knowledge of workplace health and safety requirements

US497 Co Ma Pr Se So Cr Internal 3 credits

Describe care and timeliness as an employee

US4249 Co Pr Internal 3 credits

Describe motor vehicle safe motoring requirements and general locations of systems and components

US15408 Ma Internal 4 credits

Identify the occupational areas and structure of the New Zealand Motor Industry

US21857 Ma Internal 2 credits

PW2001

Getting ready for work

NCEA Level 2

Pathways Education helps you develop skills and knowledge for an employment environment. The course offers seven modules. All students will begin in the first module PW2001 to complete the diagnostic, Moving On. They can then complete this module or choose any of the other modules.

Please note that students may need a work placement for some standards. This can be voluntary work, a part time job, work experience or a Gateway placement. PW2007 Automotive Skills is a restricted course and you will need to apply to your Pathways teacher.

Recommended prior learning: Students should have a reasonable level of literacy.

This course is booklet-based – you may download booklets in PDF format from our Online Teaching and Learning Environment (OTLE) or receive printed booklets through the post to complete and return for assessment.

If you are a secondary dual student, you must have access to a computer to download the PDF course booklets.

Apply a problem solving method to a problem

US7123 Pr So Cr Internal 2 credits

Describe an employment relationship, and the application of employment law to that relationship

US1979 Cr Internal 3 credits

Demonstrate knowledge of diversity in the workplace

US377 Pr SSe SSo Cr Internal 2 credits

Produce a personal targeted CV (curriculum vitae)

US4252 Pr So Cr Internal 2 credits

Produce a plan to enhance own learning

US7117 So Cr Internal 2 credits

PW2002

Skills for work

NCEA Level 2

Pathways Education helps you develop skills and knowledge for an employment environment. The course offers seven modules. All students will begin in the first module PW2001 to complete the diagnostic, Moving On. They can then complete this module or choose any of the other modules.

Please note that students may need a work placement for some standards. This can be voluntary work, a part time job, work experience or a Gateway placement. PW2007 Automotive Skills is a restricted course and you will need to apply to your Pathways teacher.

Recommended prior learning: Students should have a reasonable level of literacy.

This course is booklet-based – you may download booklets in PDF format from our Online Teaching and Learning Environment (OTLE) or receive printed booklets through the post to complete and return for assessment.

If you are a secondary dual student, you must have access to a computer to download the PDF course booklets.

Identify support services and resources within the community

US1827 SSo Cr Internal 2 credits

Be interviewed in a formal interview

US1294 Pr So Cr Internal 2 credits

Maintain personal presentation and a positive attitude in a workplace involving customer contact

US62 Pr SSe So Cr Internal 3 credits

Be assertive in a range of specified situations

US1299 Pr So Cr Internal 4 credits

Complete a work experience placement

US10780 Pr So Internal 3 credits

PW2003**Planning for your future**

NCEA Level 2

Pathways Education helps you develop skills and knowledge for an employment environment. The course offers seven modules. All students will begin in the first module PW2001 to complete the diagnostic, Moving On. They can then complete this module or choose any of the other modules.

Please note that students may need a work placement for some standards. This can be voluntary work, a part time job, work experience or a Gateway placement. PW2007 Automotive Skills is a restricted course and you will need to apply to your Pathways teacher.

Recommended prior learning: Students should have a reasonable level of literacy.

This course is booklet-based – you may download booklets in PDF format from our Online Teaching and Learning Environment (OTLE) or receive printed booklets through the post to complete and return for assessment.

If you are a secondary dual student, you must have access to a computer to download the PDF course booklets.

Explore career options and their implications

US12383	Pr Cr	Internal	3 credits
---------	-------	----------	-----------

Produce a plan for own future directions

US10781	Pr Cr	Internal	3 credits
---------	-------	----------	-----------

Describe the future financial responsibilities of utilising tertiary study funding options

US28093	Cr	Internal	3 credits
---------	----	----------	-----------

Describe implications of independent living, including renting and flatting

US12354	Cr	Internal	4 credits
---------	----	----------	-----------

Demonstrate knowledge of job search skills

US4253	Pr So Cr	Internal	3 credits
--------	----------	----------	-----------

Make an informed decision relating to personal income and explain its consequences

US24699	Pr Se Cr	Internal	2 credits
---------	----------	----------	-----------

PW2004**Early childhood**

NCEA Level 2

Pathways Education helps you develop skills and knowledge for an employment environment. The course offers seven modules. All students will begin in the first module PW2001 to complete the diagnostic, Moving On. They can then complete this module or choose any of the other modules.

Please note that students may need a work placement for some standards. This can be voluntary work, a part time job, work experience or a Gateway placement. PW2007 Automotive Skills is a restricted course and you will need to apply to your Pathways teacher.

Recommended prior learning: Students should have a reasonable level of literacy.

This course is booklet-based – you may download booklets in PDF format from our Online Teaching and Learning Environment (OTLE) or receive printed booklets through the post to complete and return for assessment.

If you are a secondary dual student, you must have access to a computer to download the PDF course booklets.

Describe the basic needs of children in an ECE service

US10021	SSo	Internal	3 credits
---------	-----	----------	-----------

Demonstrate knowledge of promoting the health and well-being of children in an ECE service

US10024	SSo	Internal	3 credits
---------	-----	----------	-----------

Be assertive in a range of specified situations

US1299	Pr So Cr	Internal	4 credits
--------	----------	----------	-----------

Identify support services and resources within the community

US1827	SSo Cr	Internal	2 credits
--------	--------	----------	-----------

PW2005**Customer service**

NCEA Level 2

Pathways Education helps you develop skills and knowledge for an employment environment. The course offers seven modules. All students will begin in the first module PW2001 to complete the diagnostic, Moving On. They can then complete this module or choose any of the other modules.

Please note that students may need a work placement for some standards. This can be voluntary work, a part time job, work experience or a Gateway placement. PW2007 Automotive Skills is a restricted course and you will need to apply to your Pathways teacher.

Recommended prior learning: Students should have a reasonable level of literacy.

This course is booklet-based – you may download booklets in PDF format from our Online Teaching and Learning Environment (OTLE) or receive printed booklets through the post to complete and return for assessment.

If you are a secondary dual student, you must have access to a computer to download the PDF course booklets.

Provide customer service

US57 Pr SSe So Cr Internal 2 credits

Demonstrate knowledge of diversity in the workplace

US377 Pr SSe SSo Cr Internal 2 credits

Maintain personal presentation and a positive attitude in a workplace involving customer contact

US62 Pr SSe So Cr Internal 3 credits

Communicate information in a specified workplace

US1277 Pr SSe So Cr Internal 3 credits

PW2006**Business skills**

NCEA Level 2

Pathways Education helps you develop skills and knowledge for an employment environment. The course offers seven modules. All students will begin in the first module PW2001 to complete the diagnostic, Moving On. They can then complete this module or choose any of the other modules.

Please note that students may need a work placement for some standards. This can be voluntary work, a part time job, work experience or a Gateway placement. PW2007 Automotive Skills is a restricted course and you will need to apply to your Pathways teacher.

Recommended prior learning: Students should have a reasonable level of literacy.

This course is booklet-based – you may download booklets in PDF format from our Online Teaching and Learning Environment (OTLE) or receive printed booklets through the post to complete and return for assessment.

If you are a secondary dual student, you must have access to a computer to download the PDF course booklets.

Demonstrate and apply knowledge of office equipment and administration processes

US121 SSe Cr Internal 5 credits

Communicate information in a specified workplace

US1277 Pr SSe So Cr Internal 3 credits

Write business correspondence for a workplace

US3488 So SCr Internal 6 credits

PW2007**Automotive skills**

NCEA Level 2

Pathways Education helps you develop skills and knowledge for an employment environment. The course offers seven modules. All students will begin in the first module PW2001 to complete the diagnostic, Moving On. They can then complete this module or choose any of the other modules.

Please note that students may need a work placement for some standards. This can be voluntary work, a part time job, work experience or a Gateway placement. PW2007 Automotive Skills is a restricted course and you will need to apply to your Pathways teacher.

Recommended prior learning: Students should have a reasonable level of literacy.

This course is booklet-based – you may download booklets in PDF format from our Online Teaching and Learning Environment (OTLE) or receive printed booklets through the post to complete and return for assessment.

If you are a secondary dual student, you must have access to a computer to download the PDF course booklets.

Demonstrate knowledge of traffic law for the purpose of safe driving

US3462 Co Pr Cr Internal 3 credits

Identify legal rights and obligations in relation to registering and operating a private motor vehicle

US4261 Internal 3 credits

Demonstrate knowledge of time management

US12349 Co Ma Pr So Cr Internal 3 credits

Apply a problem solving method to a problem

US7123 Pr So Cr Internal 2 credits

PCI000**Pregnancy and Childcare**

NCEA Levels 1 and 2

(course endorsement not available)

This course provides information on pregnancy, positive parenting techniques and early childhood development. It gives students the opportunity to practise food preparation skills, make and investigate the safety of toys, and observe child behaviour. Students investigate local facilities and services available.

Recommended prior learning: No prior learning needed.

This course is only available in our Online Teaching and Learning Environment (OTLE). It includes a mix of interactive online modules and downloadable booklets in PDF format, so access to a computer and broadband internet is essential. Some assessment activities may be sent to you through the post. Read more on our website at www.tekura.school.nz

Describe community services

US526 So Internal 2 credits

Analyse practices to enhance well-being used in care provision in the community

AS91303 (1a) Se SSo Internal 5 credits

Performing Arts

Ngā mahi ā te Rēhia

Performing Arts explores challenges and celebrates practical expressions of self and culture. Students have the opportunity to develop their practical performing arts skills, which can foster their creative and critical abilities, as well as enjoyment.

PA1000

Performing Arts

NCEA Levels 1 and 2

This programme offers opportunities in solo and group dance performance with the additional possibility of group music performance. A range of level 1 and level 2 standards are offered and students would complete level 1 standards in their chosen speciality before undertaking level 2 standards. The assessment focus is on individual performance, captured with quality video recording within solo/group contexts.

Recommended prior learning: Two years' or more experience is required in one or more of dance, Māori performing arts or music.

This course is only available in our Online Teaching and Learning Environment (OTLE). It includes a mix of interactive online modules and downloadable booklets in PDF format, so access to a computer and broadband internet is essential. Some assessment activities may be sent to you through the post. Read more on our website at www.tekura.school.nz

Perform dance sequences

AS90002 Cr Internal 6 credits

Demonstrate ensemble skills in a dance

AS90859 Cr Internal 4 credits

Demonstrate ensemble skills through performing a piece of music as a member of a group

AS91091 Cr Internal 4 credits

Perform an ethnic or social dance to communicate understanding of the style

AS91207 SCr Internal 4 credits

Perform a repertoire of dance

AS91209 SCr Internal 6 credits

Demonstrate ensemble skills by performing a substantial piece of music as a member of a group

AS91272 SCr Internal 4 credits

Physical Education

Mātauranga Hākinakina

In Physical Education students consider physical performances, factors that affect these performances, and work towards promoting physical activity in their community. Students have the opportunity to engage in a variety of physical activities, explore the body systems, training programmes and how to improve performances for themselves and others.

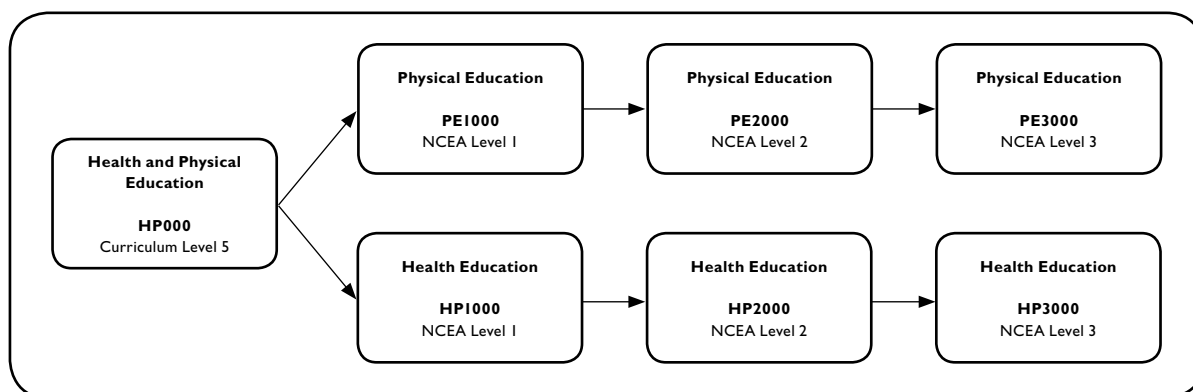

HP000

Health and Physical Education

Curriculum Level 5

In this course students explore health issues such as well-being, nutrition, communication, decision making, problem solving, safety issues around drug use, and understanding gender and sexuality. Students will also study Physical Education topics such as understanding the body, fitness testing, participating in a variety of activities, and being involved in training programmes.

Recommended prior learning: No prior learning needed.

This is an online course so access to a computer and broadband internet is essential. Read more on our website at www.tekura.school.nz

PE1000

Physical Education

NCEA Level 1 (course endorsement available)

This course follows on from HP000. In Physical Education, students study anatomy and physiology, practical performances and influences that affect participation in physical activity.

The Physical Education topics offer 19 credits towards NCEA Level 1. There are five internal standards and no external standards. Physical Education topics offer 11 Literacy credits. To gain course endorsement students need to complete 14 credits in Physical Education.

Recommended prior learning: No prior learning needed.

This course is only available in our Online Teaching and Learning Environment (OTLE). It includes a mix of interactive online modules and downloadable booklets in PDF format, so access to a computer and broadband internet is essential. Some assessment activities may be sent to you through the post. Read more on our website at www.tekura.school.nz

Participate actively in a variety of physical activities and explain factors that influence own participation

AS90962 Se So Cr Internal 5 credits

Demonstrate understanding of the function of the body as it relates to the performance of physical activity

AS90963 (1a) Pr Se So Cr Internal 5 credits

Demonstrate quality movement in the performance of a physical activity

AS90964 Se So Cr Internal 3 credits

Demonstrate strategies to improve the performance of a physical activity and describe the outcomes

AS90967 (1a) Se So Cr Internal 3 credits

Take action to enhance an aspect of personal well-being

AS90971 (1a) Pr Se So Cr Internal 3 credits

PE2000**Physical Education**

NCEA Level 2

This course follows on from PE1000 and is useful, and often essential for students intending to continue with Level 3 Physical Education courses. The Physical Education topics include biophysical principles, practical performances, influences of a training programme, and examining the impact of a sport on society.

The Physical Education topics offer 17 credits towards NCEA Level 2. There are four internal standards and no external standards. Physical Education topics also offer 13 Literacy credits. To gain course endorsement students need to complete 14 credits in Physical Education.

Recommended prior learning: NCEA Level 1 PE or equivalent

This course is booklet-based – you may download booklets in PDF format from our Online Teaching and Learning Environment (OTLE) or receive printed booklets through the post to complete and return for assessment.

If you are a secondary dual student, you must have access to a computer to download the PDF course booklets.

You may also be sent audio CDs, DVDs, equipment and/or materials through the post.

There are some optional supplementary online resources for this course which would be beneficial for your learning. Access to a computer and the internet is essential for these resources.

Demonstrate understanding of how and why biophysical principles relate to the learning of physical skills

AS91328 (la) SSe So Cr Internal 5 credits

Demonstrate understanding of the application of biophysical principles to training for physical activity

AS91329 (la) SSe SCr Internal 4 credits

Perform a physical activity in an applied setting

AS91330 Se Cr Internal 4 credits

Examine the significance for self, others and society of a sporting event, a physical activity, or a festival

AS91331 (la) Se So Cr Internal 4 credits

PE3000**Physical Education**

NCEA Level 3

This course follows on from PE2000 and is often essential for students intending to continue with Physical Education courses at tertiary institutions. Students have the opportunity to study topics on analysing an activity, practical performances, evaluating a training programme, evaluating safety management and examining an issue in society.

The Physical Education topics offer 18 credits towards NCEA Level 3. There are five internal standards worth 18 credits and no external standards. These Physical Education topics also offer 14 Literacy credits and four numeracy credits. To gain course endorsement or entry to a tertiary institution you will need to complete 14 credits in Physical Education.

Recommended prior learning: NCEA Level 2 Physical Education or equivalent.

This course is booklet-based – you may download booklets in PDF format from our Online Teaching and Learning Environment (OTLE) or receive printed booklets through the post to complete and return for assessment.

If you are a secondary dual student, you must have access to a computer to download the PDF course booklets. You may also be sent audio CDs, DVDs, equipment and/or materials through the post.

There are some optional supplementary online resources for this course which would be beneficial for your learning. Access to a computer and the internet is essential for these resources.

Analyse a physical skill performed by self or others

AS91499 (la) Internal 3 credits

Evaluate the effectiveness of a performance improvement programme

AS91500 (lna) UEna Internal 4 credits

Demonstrate quality performance of a physical activity in an applied setting

AS91501 (na) UEna Internal 4 credits

Examine a current physical activity event, trend, or issue and its impact on New Zealand society

AS91502 (la) UEIra Internal 4 credits

Analyse issues in safety management for outdoor activity to devise safety management strategies

AS91504 (la) Internal 3 credits

Physics

Te Mātauranga Ahupūngao

Physics offers an insight into the fundamental ways the world works scientifically, and its relationship with technology. Essentially it is the study of the matter and energy that makes up the physical world. This includes topics such as light, sound, heat, movement, forces, atomic physics as well as electricity and magnetism. Students will encounter many key scientific ideas and concepts that support study in other science subjects and related areas such as engineering and health science.

PH1000

Physics

NCEA Level 1 (course endorsements available)

This is an introductory course into the study of Physics, which features the main themes of heat, electricity and waves. Over the duration of the course, students will gain an understanding of the basic concepts in Physics.

Students who wish to study Physics at level 2 may enrol in this course and in the mechanics standard AS90940, which is offered under the SCI1000 course. Your selection must include at least one externally assessed standard.

Recommended prior learning: Students should have a reasonable level of literacy and numeracy.

This course is only available in our Online Teaching and Learning Environment (OTLE). It includes a mix of interactive online modules and downloadable booklets in PDF format, so access to a computer and broadband internet is essential. Some assessment activities may be sent to you through the post. Read more on our website at www.tekura.school.nz

Carry out a practical physics investigation that leads to a linear mathematical relationship, with direction

AS90935 (na) UEna Co Ma Pr So Cr Internal 4 credits

Demonstrate understanding of the physics of an application

AS90936 (la) Co Ma Pr So Cr Internal 2 credits

Demonstrate understanding of aspects of electricity and magnetism

AS90937 (na) UEna Co Ma Cr External 4 credits

Demonstrate understanding of aspects of wave behaviour

AS90938 (na) UEna Co Ma Cr External 4 credits

Demonstrate understanding of aspects of heat

AS90939 (na) UEna Co Ma Pr Cr External 4 credits

Demonstrate understanding of aspects of mechanics

AS90940 (na) UEna Co Ma Pr Se So Cr External 4 credits

PH2000

Physics

NCEA Level 2 (course endorsement available)

This course is for students interested in studying sciences, engineering, medicine, veterinary science and for those who are interested in careers as pilots, medical laboratory assistants and electricians. This course features the main themes mechanics, waves, electricity and atomic and nuclear physics. It is suitable for students who have successfully studied some physics and mathematics at NCEA Level 1. This course offers 26 credits of which 16 are externally assessed by NCEA examination in November.

Recommended prior learning: NCEA Level 1 Physics or equivalent.

This course is booklet-based – you may download booklets in PDF format from our Online Teaching and Learning Environment (OTLE) or receive printed booklets through the post to complete and return for assessment.

If you are a secondary dual student, you must have access to a computer to download the PDF course booklets.

You may also be sent audio CDs, DVDs, equipment and/or materials through the post.

There are some optional supplementary online resources for this course which would be beneficial for your learning. Access to a computer and the internet is essential for these resources.

Carry out a practical physics investigation that leads to a non-linear mathematical relationship

AS91168 (lna) UEna Co Ma Pr So Cr Internal 4 credits

Demonstrate understanding of physics relevant to a selected context

AS91169 (la) Co Ma Pr So Cr Internal 3 credits

Demonstrate understanding of waves

AS91170 UEna Co Ma Pr So Cr External 4 credits

Demonstrate understanding of mechanics

AS91171 UEna Co Ma Pr So Cr External 6 credits

Demonstrate understanding of atomic and nuclear physics
AS91172 (1a) Co Ma So Cr Internal 3 credits

Demonstrate understanding of electricity and electromagnetism
AS91173 Co Ma Pr So Cr External 6 credits

PH3000

Physics

NCEA Level 3 (course endorsement available)

This course is designed for students interested in studying sciences, engineering, medicine and veterinary science at tertiary level and other physics related technical studies at diploma level.

This course features the main themes mechanics, waves, electricity and modern physics. It builds on the theory already covered in Level 2 physics; so it is essential that students who intend to study this course should have successfully completed NCEA Level 2 physics and must have studied trigonometry, algebra and graphing in Level 2 mathematics.

This course offers 29 credits of which 16 are externally assessed by NCEA examination in November.

Recommended prior learning: NCEA Level 2 Physics or equivalent. Students with limited prerequisite are advised to contact a physics teacher to discuss their programme.

This course is booklet-based – you may download booklets in PDF format from our Online Teaching and Learning Environment (OTLE) or receive printed booklets through the post to complete and return for assessment.

You may also be sent audio CDs, DVDs, equipment and/or materials through the post.

There are some optional supplementary online resources for this course which would be beneficial for your learning. Access to a computer and the internet is essential for these resources.

This is an online course, so access to a computer and broadband internet is essential. Read more on our website at www.tekura.school.nz

Carry out a practical investigation to test a physics theory relating two variables in a non-linear relationship
AS91521 (1a) Internal 4 credits

Demonstrate understanding of the application of physics to a selected context
AS91522 (1a) Internal 3 credits

Demonstrate understanding of wave systems
AS91523 (1a) External 4 credits

Demonstrate understanding of mechanical systems
AS91524 (1a) External 6 credits

Demonstrate understanding of Modern Physics
AS91525 (1a) Internal 3 credits

Demonstrate understanding of electrical systems
AS91526 (1a) External 6 credits

Use physics knowledge to develop an informed response to a socio-scientific issue
AS91527 (1a) UEIra Internal 3 credits

Science

Te Mātauranga Pūtaiao

Science is a discipline that provides us with a range of skills and ways of thinking that are valuable in many aspects of life and work. Have you thought about why you need to eat, why cars rust, how batteries produce electrical energy or why clouds produce rain? Science helps you discover answers to such questions. So many things are based on science and students can explore not just the world of living things, but all types of substances and how they react while gaining an understanding of concepts such as force and energy that affect the Earth and space. Many issues that confront us today, such as environmental concerns, energy use, manufacturer product claims, growing our own food, maintaining good health and raising children have scientific aspects. Many choices we make in life have a scientific perspective. It's not just learning about science but also understanding how to make sense of scientific information we are bombarded with on a daily basis.

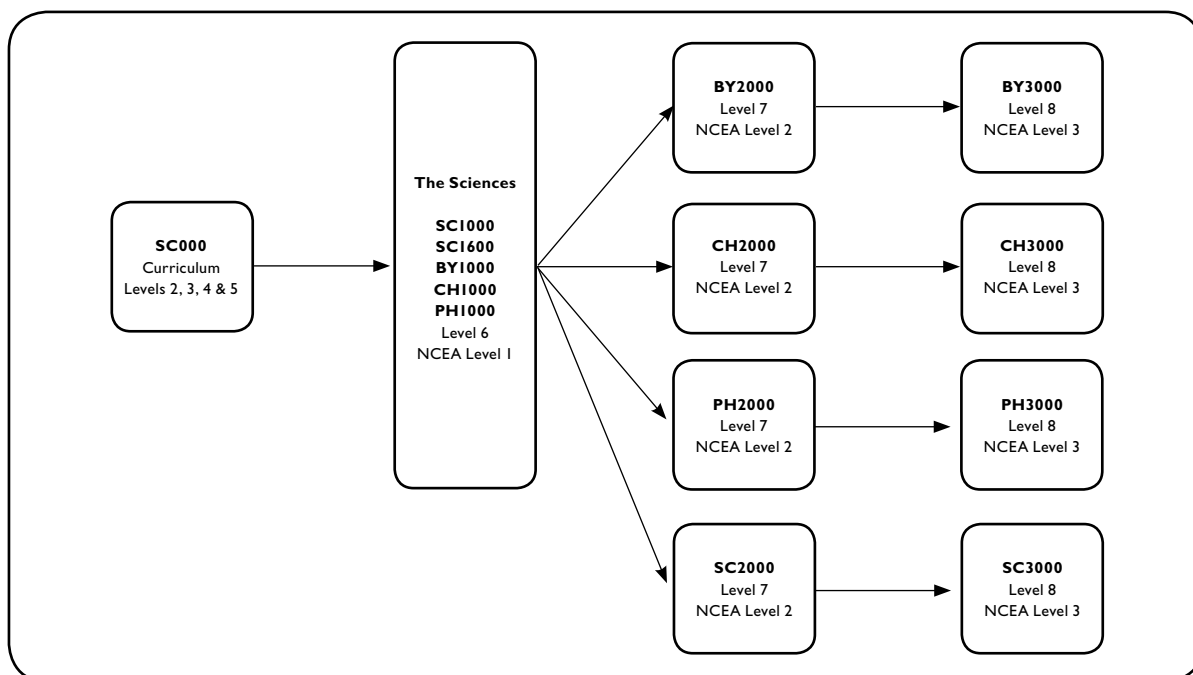

SC000

Introducing Science

Curriculum Levels 2–5

This course is aimed at students in Years 9 and above who are studying at curriculum levels 2–5. It offers a flexible programme with a wide variety of science topics which build skills and understanding. By studying the living world, the material world (chemistry), the physical world, and planet Earth and beyond, students learn about the nature of science, what science is and how scientists work. Space, electrical circuits, forces, acids and bases and how the body works are just some of the current topics. The course includes hands-on experimental work, online activities and research investigations. Students can progress through this course, year by year, up to curriculum level 5. When they have studied a range of topics at curriculum level 5, they will be well-prepared for NCEA study of the sciences.

Recommended prior learning: No prior learning needed.

This is an online course so access to a computer and broadband internet is essential. Read more on our website at www.tekura.school.nz

SCI600**Everyday Science**

NCEA Level I (course endorsement available if at least one standard achieved)

This course is for students aged 15+ who wish to work towards gaining NCEA standards in Science relevant to their goals and interests. The course includes hands-on practical activities, computer-based activities and investigations in topics from each strand of the Science curriculum.

SCI600 has the flexibility to cater to a wide range of interests and abilities. In one year, students normally study for standards offering 18–20 credits from Science at level I.

Four internally assessed achievement standards are suggested, and students can add or exchange internally assessed unit standards, internally assessed achievement standards or externally assessed achievement standards to match their interests and career goals. Students are encouraged to contact their teacher to plan their topic choices as soon as they are enrolled.

Recommended prior learning: Students should have a reasonable level of literacy and numeracy.

This course is only available in our Online Teaching and Learning Environment (OTLE). It includes a mix of interactive online modules and downloadable booklets in PDF format, so access to a computer and broadband internet is essential. Some assessment activities may be sent to you through the post. Read more on our website at www.tekura.school.nz

Demonstrate knowledge of the characteristics of living things, organs, and an organ system

US18969 Internal 2 credits

Demonstrate knowledge of matter

US18973 Internal 2 credits

Demonstrate knowledge of chemical change

US18974 Internal 2 credits

Demonstrate knowledge of the generation and use of electricity

US18977 Internal 2 credits

Demonstrate knowledge of Earth science

US18982 Internal 2 credits

Demonstrate knowledge of Earth and space

US18989 Internal 2 credits

Carry out a practical investigation in a biological context, with direction

AS90925 (na) UEna Ma Pr Se So Internal 4 credits

Report on a biological issue

AS90926 (la) Pr Internal 3 credits

Carry out a practical chemistry investigation, with direction

AS90930 (na) UEna Co Ma Pr Se Cr Internal 4 credits

Demonstrate understanding of the chemistry in a technological application

AS90931 (la) Co Ma Pr Se Cr Internal 2 credits

Carry out a practical physics investigation that leads to a linear mathematical relationship, with direction

AS90935 (na) UEna Co Ma Pr So Cr Internal 4 credits

Demonstrate understanding of the physics of an application

AS90936 (la) Co Ma Pr So Cr Internal 2 credits

Investigate implications of electricity and magnetism for everyday life

AS90941 (na) UEna Co Ma Pr Cr Internal 4 credits

Investigate implications of wave behaviour for everyday life

AS90942 (na) UEna Ma Pr Cr Internal 4 credits

Investigate implications of heat for everyday life

AS90943 (na) UEna Co Ma Pr So Cr Internal 4 credits

Investigate implications of the use of carbon compounds as fuels

AS90945 Co Ma Pr Se So Cr Internal 4 credits

Investigate selected chemical reactions

AS90947 Co Ma Pr So Cr Internal 4 credits

Investigate life processes and environmental factors that affect them

AS90949 Pr Se So Cr Internal 4 credits

Investigate biological ideas relating to interactions between humans and micro-organisms

AS90950 Co Ma Pr Se So Cr Internal 4 credits

Investigate the biological impact of an event on a New Zealand ecosystem

AS90951 Pr Se Cr Internal 4 credits

Investigate an astronomical or Earth science event

AS90955 (la) Pr So Cr Internal 4 credits

SCI000**Science**

NCEA Level 1 (course endorsement available)

This course offers a broad selection of standards in Science at level 1. In one year, students normally study for around five standards offering 18–20 credits from a menu of 31 possible achievement standards.

The wide range of standards allow a student to study different aspects of science. Students' selection of science topics and standards will be based on their interests and goals. For example, students with an interest in medical science could choose standards in genetics, microbes, acids and bases, life processes, and the biology of mammals.

Advice is available from the SCI000 course and assessment guide and from Te Kura science teachers. Teachers will help to select the right standards to ensure they study an appropriate range of standards which involve the nature of science, the physical world, the material world, the living world, and planet Earth and beyond.

Students are encouraged to do a mixture of standards assessed by both internal and external assessment. Students who are committed to a science-related career should consider choosing an additional NCEA level 1 specialist science course. The course includes hands-on experimental work, computer-based activities and research investigations. It provides a good preparation for study of the sciences at level 2.

Recommended prior learning: Students should have a reasonable level of literacy and numeracy.

This course is only available in our Online Teaching and Learning Environment (OTLE). It includes a mix of interactive online modules and downloadable booklets in PDF format, so access to a computer and broadband internet is essential. Some assessment activities may be sent to you through the post. Read more on our website at www.tekura.school.nz

Carry out a practical investigation in a biological context, with direction

AS90925 (na) UEna Ma Pr Se So Internal 4 credits

Report on a biological issue

AS90926 (la) Pr Internal 3 credits

Demonstrate understanding of biological ideas relating to micro-organisms

AS90927 (la) Ma Pr So External 4 credits

Demonstrate understanding of biological ideas relating to the life cycle of flowering plants

AS90928 (la) Pr External 4 credits

Demonstrate understanding of biological ideas relating to a mammal(s) as a consumer(s)

AS90929 (la) Pr Se So External 3 credits

Carry out a practical chemistry investigation, with direction

AS90930 (na) UEna Co Ma Pr Se Cr Internal 4 credits

Demonstrate understanding of the chemistry in a technological application

AS90931 (la) Co Ma Pr Se Cr Internal 2 credits

Demonstrate understanding of aspects of carbon chemistry

AS90932 Co Ma Pr Cr External 4 credits

Demonstrate understanding of aspects of selected elements

AS90933 Co Ma Pr Cr External 4 credits

Demonstrate understanding of aspects of chemical reactions

AS90934 Co Pr Cr External 4 credits

Carry out a practical physics investigation that leads to a linear mathematical relationship, with direction

AS90935 (na) UEna Co Ma Pr So Cr Internal 4 credits

Demonstrate understanding of the physics of an application

AS90936 (la) Co Ma Pr So Cr Internal 2 credits

Demonstrate understanding of aspects of electricity and magnetism

AS90937 (na) UEna Co Ma Cr External 4 credits

Demonstrate understanding of aspects of wave behaviour

AS90938 (na) UEna Co Ma Cr External 4 credits

Demonstrate understanding of aspects of heat

AS90939 (na) UEna Co Ma Pr Cr External 4 credits

Demonstrate understanding of aspects of mechanics

AS90940 (na) UEna Co Ma Pr Se So Cr External 4 credits

Investigate implications of electricity and magnetism for everyday life

AS90941 (na) UEna Co Ma Pr Cr Internal 4 credits

Investigate implications of wave behaviour for everyday life

AS90942 (na) UEna Ma Pr Cr Internal 4 credits

Investigate implications of heat for everyday life

AS90943 (na) UEna Co Ma Pr So Cr Internal 4 credits

Demonstrate understanding of aspects of acids and bases

AS90944 Co Ma Pr Cr External 4 credits

Investigate implications of the use of carbon compounds as fuels

AS90945 Co Ma Pr Se So Cr Internal 4 credits

Investigate selected chemical reactions

AS90947 Co Ma Pr So Cr Internal 4 credits

Demonstrate understanding of biological ideas relating to genetic variation

AS90948 (la) Ma Pr So Cr External 4 credits

Investigate life processes and environmental factors that affect them

AS90949 Pr Se So Cr Internal 4 credits

Investigate biological ideas relating to interactions between humans and micro-organisms

AS90950 Co Ma Pr Se So Cr Internal 4 credits

Investigate the biological impact of an event on a New Zealand ecosystem

AS90951 Pr Se Cr Internal 4 credits

Investigate an astronomical or Earth science event

AS90955 (la) Pr So Cr Internal 4 credits

SC2000

Science (selection)

NCEA Level 2 (course endorsement available)

This course is available to students who want a general science course at level 2 which can be done along with Social Sciences, Arts, English, Health and PE or Technology.

Science offers valuable skills and ways of thinking that benefit students as informed citizens and who are considering careers in a range of industries.

Recommended prior learning is level 1 in a Science subject. This course should not be done with BY2000, CH2000 or PH2000 due to the overlap of standards.

This course is booklet-based – you may download booklets in PDF format from our Online Teaching and Learning Environment (OTLE) or receive printed booklets through the post to complete and return for assessment.

If you are a secondary dual student, you must have access to a computer to download the PDF course booklets.

You may also be sent audio CDs, DVDs, equipment and/or materials through the post.

There are some optional supplementary online resources for this course which would be beneficial for your learning. Access to a computer and the internet is essential for these resources.

Carry out a practical investigation in a biology context, with supervision

AS91153 (na) UEna Ma Pr Se So Internal 4 credits

Analyse the biological validity of information presented to the public

AS91154 (la) Pr So Internal 3 credits

Demonstrate understanding of life processes at the cellular level

AS91156 (la) Pr So External 4 credits

Demonstrate understanding of genetic variation and change

AS91157 (la) Pr So External 4 credits

Investigate a pattern in an ecological community, with supervision

AS91158 (la) Pr Internal 4 credits

Investigate a pattern in an ecological community, with supervision

AS91158 (la) Pr Internal 4 credits

Demonstrate understanding of gene expression

AS91159 (la) Pr So External 4 credits

Carry out quantitative analysis

AS91161 (na) UEna Co Ma Pr So Cr Internal 4 credits

Demonstrate understanding of the chemistry used in the development of a current technology

AS91163 (la) Co Ma Pr Se So Cr Internal 3 credits

Demonstrate understanding of bonding, structure, properties and energy changes

AS91164 (la) Co Ma Pr So Cr External 5 credits

Demonstrate understanding of the properties of selected organic compounds

AS91165 (la) Co Ma Pr Se So Cr External 4 credits

Demonstrate understanding of chemical reactivity

AS91166 (la) Co Ma Pr Se So Cr External 4 credits

Demonstrate understanding of oxidation-reduction

AS91167 Co Ma Pr So Cr Internal 3 credits

Carry out a practical physics investigation that leads to a non-linear mathematical relationship

AS91168 (1a) UEna Co Ma Pr So Cr Internal 4 credits

Demonstrate understanding of physics relevant to a selected context

AS91169 (1a) Co Ma Pr So Cr Internal 3 credits

Demonstrate understanding of waves

AS91170 (1a) UEna Co Ma Pr So Cr External 4 credits

Demonstrate understanding of mechanics

AS91171 (1a) UEna Co Ma Pr So Cr External 6 credits

Demonstrate understanding of atomic and nuclear physics

AS91172 (1a) Co Ma So Cr Internal 3 credits

Demonstrate understanding of electricity and electromagnetism

AS91173 (1a) UEna Co Ma Pr So Cr External 6 credits

Report on the environmental impact of the production of a locally produced primary product

AS91298 (1a) SPr Internal 4 credits

SC3000

Science (selection)

NCEA Level 3 (course endorsement available)

This course is available to students who want a general science course at level 3 which can be done along with Social Sciences, Arts, English, Health and PE or Technology.

Science at this level offers valuable skills and ways of thinking that benefit students as informed citizens and who are considering careers in a range of industries.

Recommended prior learning is level 2 in a Science subject. This course should not be done with BY3000, CH3000 or PH3000 due to the overlap of standards.

This course is booklet-based – you may download booklets in PDF format from our Online Teaching and Learning Environment (OTLE) or receive printed booklets through the post to complete and return for assessment.

If you are a secondary dual student, you must have access to a computer to download the PDF course booklets.

You may also be sent audio CDs, DVDs, equipment and/or materials through the post.

There are some optional supplementary online resources for this course which would be beneficial for your learning. Access to a computer and the internet is essential for these resources.

Carry out a practical investigation in a biological context, with guidance

AS91601 (1a) UEna Internal 4 credits

Integrate biological knowledge to develop an informed response to a socio-scientific issue

AS91602 (1a) UElwra Internal 3 credits

Demonstrate understanding of the responses of plants and animals to their external environment

AS91603 (1a) UElwra External 5 credits

Demonstrate understanding of how an animal maintains a stable internal environment

AS91604 (1a) UElra Internal 3 credits

Demonstrate understanding of evolutionary processes leading to speciation

AS91605 (1a) UElwra External 4 credits

Demonstrate understanding of trends in human evolution

AS91606 (1a) UElwra External 4 credits

Demonstrate understanding of human manipulations of genetic transfer and its biological implications

AS91607 (1a) UElra Internal 3 credits

Demonstrate understanding of spectroscopic data in chemistry

AS91388 Internal 3 credits

Demonstrate understanding of chemical processes in the world around us

AS91389 (1a) UElwra Internal 3 credits

Demonstrate understanding of thermochemical principles and the properties of particles and substances

AS91390 (1a) External 5 credits

Demonstrate understanding of the properties of organic compounds

AS91391 (1a) External 5 credits

Demonstrate understanding of equilibrium principles in aqueous systems

AS91392 (1a) UEna External 5 credits

Demonstrate understanding of oxidation-reduction processes

AS91393 (1a) Internal 3 credits

Carry out a practical investigation to test a physics theory relating two variables in a non-linear relationship

AS91521 (1a) Internal 4 credits

Demonstrate understanding of the application of physics to a selected context

AS91522 (1a) Internal 3 credits

Demonstrate understanding of wave systems

AS91523 (1a) External 4 credits

Demonstrate understanding of mechanical systems

AS91524 (1a) External 6 credits

Demonstrate understanding of Modern Physics

AS91525 (1a) Internal 3 credits

Use physics knowledge to develop an informed response to a socio-scientific issue

AS91527 (1a) UElra Internal 3 credits

Social Studies

Te Akoranga Tikanga ā-iwi

In Social Studies, students learn about people, places, cultures, histories and the economic world within and beyond New Zealand. Social Studies helps students understand people by exploring different points of view and beliefs. Students are given opportunities to develop communication, critical thinking and decision-making skills. These attributes help students become responsible and informed citizens with the ability to analyse the world that surrounds them. The course for each student will be developed in consultation with the teacher to meet particular needs and interests.

SS000

Social Studies

Curriculum Levels 3–5

In this course, students will be able to investigate issues in society and the interaction of cultures both in New Zealand and globally. Topics have a past, present and future focus. Students are able to study topics such as sustainability, human rights, cultural diversity and enterprise. They will investigate how change affects New Zealand cultures, societies and communities, to help them understand the past and the present, and to imagine possible futures. Students are encouraged to explore their own ideas about issues of concern, both to themselves and the wider New Zealand and global communities.

Recommended prior learning: No prior learning needed.

This is an online course so access to a computer and broadband internet is essential. Some materials may be downloadable booklets in PDF format or sent to you through the post. Read more on our website at www.tekura.school.nz

Spanish

Te Reo Pāniora

Spanish is the third most widely spoken language and is used by over 500 million people in Spain and both North and South America. By studying Spanish, students will gain insight into a rich history that has spanned the globe, not to mention a variety of cultures and societies. Many New Zealanders are choosing to learn Spanish for its importance as both a commercial and cultural language.

PYSP

Primary Spanish

Curriculum Level 1

PYSP is a year 7 Spanish course available only online. It is a taster course which introduces basic communication in Spanish. In the course, students will learn how to greet people, how to ask where someone is from, how to talk about family, and how to ask about and give the time, as well as other everyday topics.

This course is only available to full-time years 7 and 8 students and fee payers. Students registered in this course will be required to work online on OTLE.

Recommended prior learning: No prior learning needed.

This is an online course so access to a computer and broadband internet is essential. Read more on our website at www.tekura.school.nz

SP000

Beginners' Spanish

Curriculum Levels 1–5

This is a course for beginners (Curriculum Levels 1–3). Students are introduced to basic listening, speaking, reading and writing skills using everyday Spanish. They will learn how to greet people, communicate basic information about themselves and others, including looks, hobbies, birthdays, family and their home. They also learn how to talk about food, shopping and different countries. Hispanic culture is also investigated to give students a broad understanding of the different countries and customs where Spanish is spoken. Communication activities are emphasised throughout.

Recommended prior learning: No prior learning needed.

This is an online course so access to a computer and broadband internet is essential. Some materials may be downloadable booklets in PDF format or sent to you through the post. Read more on our website at www.tekura.school.nz

If you are a secondary dual student, you must have access to a computer to download the PDF course booklets.

For this course you will be required to make and submit audio and/or video recordings, so a microphone – either separate or built into your device – is essential.

SPI000

Spanish

NCEA Level 1 (course endorsement available)

This course develops the four main language skills: listening, speaking, reading and writing. Students will hear and learn the Spanish language as it is spoken in both Spain and Latin America. Throughout the course, the style remains conversational and learning is set to a backdrop of realistic and everyday situations. From introducing oneself to describing family and friends, this course will provide students with the ability to converse socially in basic Spanish. Other topics covered include holidays and travel, school life, as well as sports and leisure activities.

Recommended prior learning: Previous basic knowledge of Spanish is an advantage but not necessary.

This course is only available in our Online Teaching and Learning Environment (OTLE). It includes a mix of interactive online modules and downloadable booklets in PDF format, so access to a computer and broadband internet is essential. Some assessment activities may be sent to you through the post. Read more on our website at www.tekura.school.nz

If you are a secondary dual student, you must have access to a computer to download the PDF course booklets.

For this course you will be required to make and submit audio and/or video recordings, so a microphone – either separate or built into your device – is essential.

Demonstrate understanding of a variety of spoken Spanish texts on areas of most immediate relevance

AS90908

Pr Se So Cr

External 5 credits

Give a spoken presentation in Spanish that communicates a personal response
AS90909 Pr Internal 4 credits

Demonstrate understanding of a variety of Spanish texts on areas of most immediate relevance
AS90911 Se External 5 credits

Write a variety of text types in Spanish on areas of most immediate relevance
AS90912 Se Cr Internal 5 credits

SP2000

Spanish

NCEA Level 2 (course endorsement available)

Over this course students will learn how to use Spanish vocabulary, structures and functions to communicate a wide range of language, for varying situations. Students will further their basic Spanish skills and be able to talk about a wide range of events, express their opinions and make comparisons and contrasts. In turn, they will gain the necessary ability to give instructions and make suggestions, and will extend their knowledge on how to use and distinguish between past, present and future tenses.

Recommended prior learning: NCEA Level 1 Spanish or equivalent.

This course is booklet-based – you may download booklets in PDF format from our Online Teaching and Learning Environment (OTLE) or receive printed booklets through the post to complete and return for assessment.

If you are a secondary dual student, you must have access to a computer to download the PDF course booklets.

There are some optional supplementary online resources for this course which would be beneficial for your learning. Access to a computer and the internet is essential for these resources.

For this course you will be required to make and submit audio and/or video recordings, so a microphone – either separate or built into your device – is essential.

Demonstrate understanding of a variety of spoken Spanish texts on familiar matters
AS91148 Se Cr External 5 credits

Interact using spoken Spanish to share information and justify ideas and opinions in different situations
AS91149 SSe So Cr Internal 5 credits

Give a spoken presentation in Spanish that communicates information, ideas and opinions
AS91150 Internal 4 credits

Demonstrate understanding of a variety of written and/or visual Spanish text(s) on familiar matters
AS91151 Se External 5 credits

Write a variety of text types in Spanish to convey information, ideas, and opinions in genuine contexts
AS91152 Se Cr Internal 5 credits

SP3000

Spanish

NCEA Level 3 (course endorsement available)

Having an understanding of the cultures that surround a language is integral to communicating. This course focuses on authentic Spanish for conversation in a variety of situations in both Latin America and Spain. Throughout, there will be many opportunities to speak Spanish, and language skills will also be furthered through exercises in listening for understanding, interest and enjoyment, along with reading and writing work that will develop an appreciation for both the language and the culture.

New Zealand Scholarship exams are designed to extend very high achieving level 3 students. Those who wish to enter for the NZ Scholarship exam in this subject must discuss this option with their Te Kura subject teacher.

Recommended prior learning: NCEA Level 2 Spanish or equivalent.

This course is booklet-based – you may download booklets in PDF format from our Online Teaching and Learning Environment (OTLE) or receive printed booklets through the post to complete and return for assessment.

If you are a secondary dual student, you must have access to a computer to download the PDF course booklets.

There are some optional supplementary online resources for this course which would be beneficial for your learning. Access to a computer and the internet is essential for these resources.

For this course you will be required to make and submit audio and/or video recordings, so a microphone – either separate or built into your device – is essential.

Demonstrate understanding of a variety of extended spoken Spanish texts

AS91568 External 5 credits

Give a clear spoken presentation in Spanish that communicates a critical response to stimulus material

AS91569 Internal 3 credits

Interact clearly using spoken Spanish to explore and justify varied ideas and perspectives in different situations

AS91570 Internal 6 credits

Demonstrate understanding of a variety of extended written and/or visual Spanish texts

AS91571 External 5 credits

Write a variety of text types in clear Spanish to explore and justify varied ideas and perspectives

AS91572 Internal 5 credits

Special Education Programme

Te Akoranga Mothake

Some students studying with Te Kura have special education needs and require significant adaptation of the curriculum. We therefore design a programme to match the needs, interests and context of the individual. We aim to meet their long and short-term goals. The courses offered under the Special Education Programme are all at Curriculum Level 1. These courses cover the seven essential learning areas. There are also two Life Skills courses at Curriculum Level 1. There is an additional Life Skills course at Curriculum Levels 2–3, refer to Index – Life Skills. Special Education courses are open to all students in the compulsory education years and to adults. Early childhood students with special education needs are enrolled and taught by our Early Childhood Service.

SEART

Special Education Art

Curriculum Level 1

This course encourages students to explore the four disciplines of visual art, music, dance and drama. In visual art, students use a variety of techniques and materials. They explore art and design in their environment and in their daily lives. Topics include collage, mosaic, sewing, creative gifts, decorations and wearable art. In music, students listen and respond to a broad range of sounds, music and visual images. They share ideas about sound and music in everyday life and explore ways to create and represent sound.

Recommended prior learning: No prior learning needed.

SEENG

Special Education English

Curriculum Level 1

A broad course that covers all major areas of the English curriculum. This includes developing literacy, listening and speaking, along with teaching students how to view and present work. Students take part in a range of learning activities, and each programme is designed to meet the specific learning needs and interests of the individual.

Recommended prior learning: No prior learning needed.

SEHPE

Special Education Health and PE

Curriculum Level 1

This course is designed to help develop students' abilities in the area of health and physical education. The four strands of the curriculum are covered: relationships with other people, movement concepts and motor skills, healthy communities and environments, and personal health and physical development.

Recommended prior learning: No prior learning needed.

SELS

Special Education Life Skills

Curriculum Level 1

This course is designed for students working at the very earliest stages of curriculum level 1. Learning materials are selected to help students develop some basic living skills. This could include material from a range of subject areas. Programmes are designed in collaboration with the supervisor or learning support teacher and reflect the age, interests, abilities and context of the student.

Recommended prior learning: No prior learning needed.

SEMAS

Special Education Maths

Curriculum Level 1

This course offers the curriculum level 1 strands in mathematics and statistics and topics for emerging level 1 students. Emerging level 1 covers basic concepts of colour, shape, size and position. The curriculum level 1 topics explore numeracy stages 0–4, algebra, geometry and measurement.

Recommended prior learning: No prior learning needed.

SESCI

Special Education Science

Curriculum Level 1

This course is designed to help develop early scientific understandings and competencies. Learning is based on practical activities, and students are encouraged to ask questions, investigate, test ideas and communicate their observations about the natural, physical and material worlds, and the universe beyond. Students will be introduced to a diverse range of scientific subjects and how they

relate to the everyday world, from outer space and dinosaurs through to shadows, insects and chemistry in the kitchen.

Recommended prior learning: No prior learning needed.

SESST

Special Education Social Studies

Curriculum Level I

This course looks at various social contexts both past and present, from New Zealand and the world. The topics covered are designed to encourage and develop skills of questioning, gathering and presenting information. The four main areas investigated are: identity, culture and organisation; place and environment; continuity and change; and the economic world.

Recommended prior learning: No prior learning needed.

SETEC

Special Education Technology

Curriculum Level I

This course aims to build knowledge and confidence in using everyday technology, and allows students to participate in a constantly changing world. Throughout the course, students take part in a range of practical work from cooking pikelets to sending messages. Other topics include making your own book, posting a parcel and framing a picture.

Recommended prior learning: No prior learning needed.

SLS100

Supported Learning Standards

Curriculum Level I

Supported Learning Standards are intended for students at year 10 and above working with support at curriculum level I. Students can work towards achieving the National Certificate in Work and Community Skills (40 credits). Throughout this course students can develop skills and knowledge in three domains i.e. personal care, interpersonal and social skills, work and community skills – this domain includes communication and numeracy.

If it was felt that a student would benefit from aspects of this course due to their psychological or physical condition, even though they are working above curriculum level I in other subject areas, consideration would be given by the curriculum leader of Special Education to approving enrolment on a case-by-case basis. Students must have the support of a teacher aide who acts as the verifier for the assessments.

Recommended prior learning: No prior learning needed.

Identify and locate organs in the human body, in a supported learning context

US11854 Internal 2 credits

Demonstrate knowledge of self-care for minor illness or condition, and injury, in a supported learning context

US11860 Internal 2 credits

Demonstrate knowledge of personal hygiene, in a supported learning context

US11861 Internal 3 credits

Cross roads safely, in a supported learning context

US11865 Internal 4 credits

Answer a phone call and refer a phone call, in a supported learning context

US11867 Internal 2 credits

Make phone calls, in a supported learning context

US11869 Internal 1 credits

Purchase goods in a shop, in a supported learning context

US11876 Internal 1 credits

Select and wear clothes for different occasions and identify need to care for clothes, in a supported learning context

US11877 Internal 1 credits

Grow and care for plants, in a supported learning context

US11879 Internal 2 credits

Prepare and serve a light meal, in a supported learning context

US11882 Internal 4 credits

Handle money, in a supported learning context

US11888 Internal 3 credits

Make deposits into and withdrawals from own bank account, in a supported learning context

US11889 Internal 2 credits

Use a calculator to assist with functional numeracy, in a supported learning context

US11890 Internal 2 credits

Demonstrate functional knowledge of measuring length, in a supported learning context

US11891 Internal 3 credits

Demonstrate functional knowledge of measuring weight, in a supported learning context

US11893 Internal 3 credits

Demonstrate functional knowledge of measuring time, in a supported learning context

US11894 Internal 4 credits

Use a calendar, in a supported learning context

US11896 Internal 2 credits

Identify and use numbers one to ten in everyday life, in a supported learning context

US11897 Internal 2 credits

Identify and use numbers ten to one hundred in everyday life, in a supported learning context

US11898 Internal 3 credits

Produce, save, and print a text document on a computer, in a supported learning context

US11900 Internal 4 credits

Receive, record, and deliver messages, in a supported learning context

US11914 Internal 2 credits

Clarify and follow received instructions, in a supported learning context

US11918 Internal 2 credits

Identify traditional occasions in own family, in a supported learning context

US11921 Internal 2 credits

Demonstrate knowledge of friendships or relationships, in a supported learning context

US20075 Internal 3 credits

Te Ara Hou Integrated Programme

Te Ara Hou

Integrated studies for Year 7–10 students.

INTGR8**Te Ara Hou**

Curriculum Levels 2–5

Years 7–10. Te Ara Hou: Learning pathways Curriculum Levels 2–5. Full-time students in Years 7–10 are taught in the Te Ara Hou programme with curriculum delivery through either a fully integrated programme of learning; individual subjects; or, most commonly, a partially integrated programme. Students learn with a dedicated learning advisor who works with the student, family/whānau to develop the most suitable programme of learning for students. Learning programmes reflect the levels of achievement and strands as outlined in the New Zealand Curriculum (2007).

Integrated units of work are organised around a key concept through which students explore real-life problems and concepts, both concrete and abstract. Students have opportunities to use creative, critical and metacognitive processes to make sense of information, experiences and ideas, benefiting year 9 and 10 students as they prepare for NCEA assessment. Online learning is a requirement of all courses.

Recommended prior learning: No prior learning needed.

Print-based, Online supported.

Technology

Te Mātauranga Hangarau

Students who enjoy designing and making things should enrol in this subject. Technology students can choose to work in food technology, hard materials and fashion/textiles technology. Students use the design process and develop their technological skills in contexts that interest them. Technology encourages students to think creatively and design practical solutions to problems they have identified. Students are expected to work with people and with resources in their community so that their projects are meaningful and authentic.

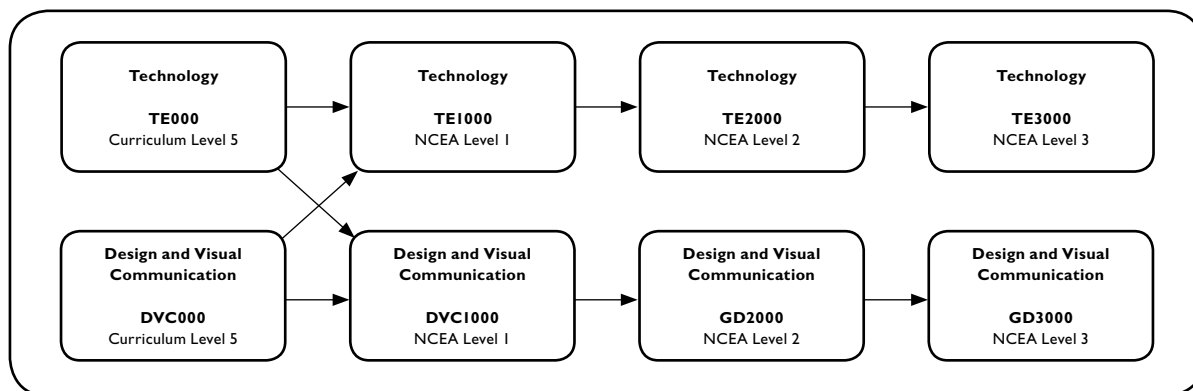

TE000

Technology

Curriculum Level 5

This exciting course offers students a variety of learning opportunities to explore, design and create solutions to authentic practical problems. Students develop their technological practice by a pick and mix of topics from any technological area. They can also specialise in one if they wish.

Topics are based on student interests and develop practical technological skills in design and construction. In some topics, wider issues such as sustainability and the impact of technology on the environment and society are introduced. Students are guided to understand the designer/stakeholder relationship, to identify issues, gather research and think in a visual way as they plan and make in a range of materials.

Recommended prior learning: No prior learning needed.

This is an online course so access to a computer and broadband internet is essential. Read more on our website at www.tekura.school.nz

TE1000

Technology

NCEA Level 1 (course endorsement available)

This course is for students who like designing and creating practical solutions in real life situations. Technology students work with people (stakeholders) in a setting that interests them.

Technology offers topics in food technology, hard materials and soft materials (fashion/textiles) and students can choose from a number of different topics or they can specialise in one. Worksheets are used to guide students to develop their design, investigation, planning and construction skills. Students are also encouraged to think creatively and communicate visually as they develop their technological practice and apply their technological knowledge.

Recommended prior learning: No prior learning needed.

This course is only available in our Online Teaching and Learning Environment (OTLE). It includes a mix of interactive online modules and downloadable booklets in PDF format, so access to a computer and broadband internet is essential. Some assessment activities may be sent to you through the post. Read more on our website at www.tekura.school.nz

Demonstrate knowledge of and apply safe working practices in the construction of a BCATS project

US24352

Co Pr

Internal 2 credits

Demonstrate knowledge of construction and manufacturing materials used in BCATS projects
US24355 Co Pr Internal 4 credits

Apply elementary workshop procedures and processes for BCATS projects
US24356 Co Pr Internal 8 credits

Undertake brief development to address a need or opportunity
AS91044 (la) Co Ma Pr Se Cr Internal 4 credits

Use design ideas to produce a conceptual design for an outcome to address a brief
AS91046 Co Ma Pr Cr Internal 6 credits

Undertake development to make a prototype to address a brief
AS91047 Co Ma Pr Cr Internal 6 credits

Demonstrate understanding of how technological modelling supports decision-making
AS91048 (la) Co Ma Pr Cr External 4 credits

Implement basic procedures using resistant materials to make a specified product
AS91057 Co Ma Pr Internal 6 credits

Implement basic procedures using textile materials to make a specified product
AS91058 Co Ma Cr Internal 6 credits

Demonstrate understanding of basic concepts used to make products from textile materials
AS91060 (la) Co Ma Cr Internal 4 credits

Use the work of an influential designer to inform design ideas
AS91067 Ma Cr Internal 3 credits

Implement basic procedures to process a specified product
AS91082 Ma Pr Se Internal 4 credits

Make basic adaptations to a pattern to enable a design to fit a person or item
AS91096 Ma Cr Internal 4 credits

TE2000

Technology

NCEA Level 2 (course endorsement available)

This course is for students who enjoy innovating and creating practical 'things'. Students chose an area that interests them (food technology, hard materials, and fashion and textiles) and work with people to identify authentic opportunities to design, develop and construct technological solutions.

Students work creatively to combine function and aesthetics, and consider a technologist's responsibility to the wider community. Students follow a case study that models the design process, the designer/stakeholder relationship, and provides practical teaching and guidance. Students use this to develop their understanding of design, visual thinking, investigation, planning and construction.

Recommended prior learning: NCEA Level 1 Technology or equivalent.

This course is booklet-based – you may download booklets in PDF format from our Online Teaching and Learning Environment (OTLE) or receive printed booklets through the post to complete and return for assessment.

If you are a secondary dual student, you must have access to a computer to download the PDF course booklets.

There are some optional supplementary online resources for this course which would be beneficial for your learning. Access to a computer and the internet is essential for these resources.

Implement advanced procedures using resistant materials to make a specified product with special features
AS91344 SCo SMa SCr Internal 6 credits

Implement advanced procedures using textile materials to make a specified product with special features
AS91345 SCo SMa SCr Internal 6 credits

Make advanced adaptations to a pattern to change the structural and style features of a design
AS91350 SCo SMa SCr Internal 4 credits

Implement advanced procedures to process a specified product
AS91351 SMa Pr Se Internal 4 credits

Undertake brief development to address an issue
AS91354 (la) Co Ma Pr Cr Internal 4 credits

Develop a conceptual design for an outcome
AS91356 Co Ma Pr SCr Internal 6 credits

Undertake effective development to make and trial a prototype
AS91357 Co SMa Pr SCr Internal 6 credits

Demonstrate understanding of how technological modelling supports risk management
AS91358 (la) Co Ma External 4 credits

TE3000**Technology**

NCEA Level 3 (course endorsement available)

TE3000 challenges students to identify authentic opportunities for innovative design work within their community. A setting is provided, students identify an opportunity that interests them and then choose a context to work in, including food technology, hard or soft materials (fashion/textiles), frequently working in a combination of these.

This course widens their experience of the design process from concept to completion. Students work closely with stakeholders as they plan, design and model their concepts before finally creating a solution that is fit for purpose.

New Zealand Scholarship exams are designed to extend very high achieving level 3 students. Those who wish to enter for the NZ Scholarship exam in this subject must discuss this option with their Te Kura subject teacher.

Recommended prior learning: NCEA Level 2 Technology or equivalent.

This is an online course, so access to a computer and broadband internet is essential. Read more on our website at www.tekura.school.nz

Undertake brief development to address an issue within a determined context

AS91608 (la) Internal 4 credits

Develop a conceptual design considering fitness for purpose in the broadest sense

AS91610 (la) Internal 6 credits

Develop a prototype considering fitness for purpose in the broadest sense

AS91611 (la) Internal 6 credits

Demonstrate understanding of how technological modelling supports technological development and implementation

AS91612 (la) UElwa External 4 credits

Demonstrate understanding of material development

AS91613 (la) UElwa External 4 credits

Undertake a critique of a technological outcome's design

AS91617 (la) UElwa External 4 credits

Undertake development and implementation of a green manufacturing process

AS91618 (la) Internal 6 credits

Implement complex procedures to integrate parts using resistant materials to make a specified product

AS91620 Internal 6 credits

Implement complex procedures using textile materials to make a specified product

AS91621 Internal 6 credits

Implement complex procedures to create an applied design for a specified product

AS91623 Internal 4 credits

Draft a pattern to interpret a design for a garment

AS91626 Internal 6 credits

Implement complex procedures to process a specified product

AS91643 (la) Internal 6 credits

Demonstrate understanding of combined preservation mechanisms used to maintain product integrity

AS91644 (la) Internal 4 credits

Te Reo Māori

Te Reo Māori

Māori is one of the official languages of New Zealand and an integral part of the country's culture. There are numerous reasons to learn Māori from personal enjoyment to career requirements. Whatever it may be, learning Māori will not only provide great satisfaction, but a greater connection with New Zealand and an enhanced understanding of our culture and society.

PYTREO

Ka Mau Te Wehi

Curriculum Level I

PYTREO is a Year 7 Te Reo Māori course called Ka Mau Te Wehi. It is offered as an online course or as a DVD/Audio CD booklet course. It is a taster course that introduces Te Reo Māori with short videos of everyday situations. In the course students will learn how to greet people, how to introduce people, how to express likes, how to count in Māori, how to talk about time and to ask where something is as well as other everyday topics.

Recommended prior learning: No prior learning needed.

This course is booklet-based – you may download booklets in PDF format from our Online Teaching and Learning Environment (OTLE) or receive printed booklets through the post to complete and return for assessment.

You may also be sent audio CDs, DVDs, equipment and/or materials through the post.

This is an online course so access to a computer and broadband internet is essential. Read more on our website at www.tekura.school.nz

MA000

Beginners' Māori

Curriculum Levels 1–5

This is a course for beginners. Students are introduced to basic listening, speaking, reading and writing skills using everyday Te Reo Māori. They will learn how to greet people, communicate basic information about themselves and others, including weather, colours, birthdays, family and their home. They also learn how to communicate about roles and responsibilities on the marae, time, body parts, food and shopping. Māori culture is also investigated to give students a broad understanding of the different dialects and customs where Māori is spoken. Communication activities are emphasised throughout.

Recommended prior learning: No prior learning needed.

This course includes booklet-based materials which will be sent through the post to complete and return for assessment. You will also be sent CDs through the post.

For this course you will be required to make and submit audio and/or video recordings, so a microphone – either separate or built into your device – is essential.

MA1000

Te Reo Māori

NCEA Level I

A range of themes and skills will be practised through listening, speaking, reading and writing in Māori. The topics covered in this course are: Kei te Kainga, Te Ao Taiohi, Kei te Marae and Kei te Kura. Students are required to have two or more years' experience in Māori language. Additional possibility: Performing Arts offers dance and music standards. Students are expected to have two years or more experience in Māori Performing Arts or Dance or Music. Students will be assessed individually, or as part of a group.

Recommended prior learning: Students should be able to use Te Reo flexibly in an every day context.

This is an online course so access to a computer and broadband internet is essential. Read more on our website at www.tekura.school.nz

For this course you will be required to make and submit audio and/or video recordings, so a microphone – either separate or built into your device – is essential.

Perform dance sequences

AS90002 Cr Internal 6 credits

Demonstrate ensemble skills in a dance

AS90859 Cr Internal 4 credits

Whakarongo kia mōhio ki te reo o tōna ao

AS91085 (la) Pr Se So Cr Internal 6 credits

Kōrero kia whakamahi i te reo o tōna ao

AS91086 (la) Pr Se So Cr Internal 6 credits

Pānui kia mōhio ki te reo o tōna ao

AS91087 (la) Pr Se So Cr External 6 credits

Tuhi i te reo o tōna ao

AS91088 (la) Pr Se So Cr External 6 credits

Waihanga tuhinga i te reo o tōna ao

AS91089 (la) Pr Se So Cr Internal 6 credits

Demonstrate ensemble skills through performing a piece of music as a member of a group

AS91091 Cr Internal 4 credits

MA2000

Te Reo Māori

NCEA Level 2

A range of themes and skills will be practised through listening, speaking, reading and writing in Māori. The following topics will be covered: Ōku wawata, He Huihuinga, Tangata Autaia and Ngā Pūrākau Rongonui. Students are required to have three or more years experience in Māori language. Additional possibility: Performing Arts offers dance and music standards. Students are expected to have two years or more experience in Māori Performing Arts or Dance or Music. Students will be assessed individually, or as part of a group.

Recommended prior learning: NCEA Level 1 Māori or equivalent.

This is an online course so access to a computer and broadband internet is essential. Read more on our website at www.tekura.school.nz

For this course you will be required to make and submit audio and/or video recordings, so a microphone – either separate or built into your device – is essential.

Perform an ethnic or social dance to communicate understanding of the style

AS91207 SCr Internal 4 credits

Perform a repertoire of dance

AS91209 SCr Internal 6 credits

Demonstrate ensemble skills by performing a substantial piece of music as a member of a group

AS91272 SCr Internal 4 credits

Whakarongo kia mōhio ki te reo o te ao torotoro

AS91284 (la) Pr Se So Cr Internal 4 credits

Kōrero kia whakamahi i te reo o te ao torotoro

AS91285 (la) Pr SSe So Cr Internal 6 credits

Pānui kia mōhio ki te reo o te ao torotoro

AS91286 (la) UElra Pr Se So Cr External 6 credits

Tuhi i te reo o te ao torotoro

AS91287 (la) UElwa Pr Se So Cr External 6 credits

Waihanga tuhinga auaha, i te reo o te ao torotoro

AS91288 (la) UElwa Pr SSe So Cr Internal 6 credits

MA3000

Te Reo Māori

NCEA Level 3 (course endorsement available)

A range of themes and skills will be practised and extended through listening, speaking, reading and writing in Māori. The following topics will be covered: He Mahi Whakangūngū, Ngā Waihanga Tuhinga, Ngā Ahuatanga Whakarongo and Ngā Ahuatanga Kōrero. Students are required to have completed at least four years or more in Māori Language. This level of Māori requires a wide range of vocabulary and grammar skills.

Recommended prior learning: NCEA Level 2 Māori or equivalent. Students are expected to have four years or more experience in Māori language.

This is an online course so access to a computer and broadband internet is essential. Read more on our website at www.tekura.school.nz

For this course you will be required to make and submit audio and/or video recordings, so a microphone – either separate or built into your device – is essential.

Whakarongo kia mōhio ki te reo Māori o te ao whanui

AS91650 (la) Internal 4 credits

Kōrero kia whakamahi i te reo Māori o te ao whanui

AS91651 (la) Internal 6 credits

Pānui kia mohio ki te reo Māori o te ao whanui

AS91652 (la) UElra External 6 credits

Tuhi i te reo Māori o te ao whanui

AS91653 (la) UElwa External 6 credits

Waihanga tuhinga whai take i te reo Māori o te ao whanui

AS91654 (la) UElwa Internal 6 credits

Tertiary Link/Huarahi Trades Academy

Te Wānanga Hononga/Huarahi

Year 12 and 13 full-time students and full-time young adults can take a Tertiary Link course. These courses are purchased from outside providers and students can gain standards towards National Certificates through these courses. Year 11–13 full-time students and full-time young adults can apply for a place in Huarahi Trades Academy. We have partners throughout New Zealand where our students can attend a tertiary programme for one or two days a week working towards a vocational pathway. Most Trades Academy programmes can only be started at the beginning of the year but there is provision with some providers to start mid-year or at any time during the year.

TERTLNK

Tertiary Link

NCEA Levels 1 and 2

Options available are:

Automotive – Distance units available from Fairview Educational Services at NCEA Level 2.

Early Childhood Education – Distance units available from Porse Network at NCEA Levels 2 and 3. Practical experience looking after a child under the age of five years is required either at home or in a workplace. Students can work towards the National Certificate in Early Childhood Education Level 3.

Farm Based Skills – Distance units available from Telford Rural Polytechnic. A wide range of unit standards available at NCEA Levels 2 and 3 in General Agriculture, Vehicles and Machinery, Fencing, Dairy, Deer, Sheep, Cattle, Farming Agrichemicals and pest plant control, Apiculture (Beekeeping), Equine, Horticulture and Forestry.

Travel – Distance units available from Travel Careers and Training at NCEA Levels 2 and 3. Students can gain the National Certificate in Tourism (Introductory Skills) Level 2.

Recommended prior learning: No prior learning needed.

This course is only available in our Online Teaching and Learning Environment (OTLE). It includes a mix of interactive online modules and downloadable booklets in PDF format, so access to a computer and broadband internet is essential. Some assessment activities may be sent to you through the post. Read more on our website at www.tekura.school.nz

HUARIHI TRADES ACADEMY

Huarahi Trades Academy

NCEA Levels 1 and 2

Huarahi Trades Academy offers students possibilities for achieving NCEA Level 2 and standards towards a Vocational Pathway endorsement, in partnership with tertiary providers. We have a range of tertiary providers across New Zealand and do our best to offer a course to match your career interests while you also complete your school work.

Not all programmes are offered in all areas so it is worth asking or checking on the Te Kura website.

Students can complete the qualifications over one, two or three years, while students remain on target to achieve NCEA Level 2. Students must complete a registration form and an interview process. Trades Academy places are limited.

Recommended prior learning: Students must be working at NCEA Level 1 or 2.

This course is only available in our Online Teaching and Learning Environment (OTLE). It includes a mix of interactive online modules and downloadable booklets in PDF format, so access to a computer and broadband internet is essential. Some assessment activities may be sent to you through the post. Read more on our website at www.tekura.school.nz

Years 1 to 6

Tau I ki te 6

Te Kura's learning programme is based on the eight learning areas in the New Zealand Curriculum – English, The Arts, Health and Physical Education, Learning Languages, Mathematics and Statistics, Science, Social Sciences, and Technology.

Students in Years 1–6 are allocated a learning advisor (teacher) according to their geographical region. Learning advisors work closely with parents and supervisors to develop an individualised programme for each student, based on their interests, abilities and learning needs, with support from whānau and community.

A personalised Student Education Plan (SEP) is developed together. The SEP records a student's agreed aspirational goals. Regular review of a student's SEP measures progress made and provides the opportunity for setting new goals.

Students will have the opportunity to meet their learning advisor or other Te Kura teachers at event days and other organised activities throughout the year.

We use a mix of online, print and digital delivery. Students are able to learn in an online class and can contact their learning advisor via email, Skype, Adobe Connect or through our Online Teaching and Learning Environment (OTLE), as well as via telephone and through the post. Students based outside New Zealand will access most of their course materials digitally.

Attendance

In New Zealand, students between the ages of 6 and 16 must be enrolled in a school and must attend school. For Te Kura students, attendance means that assessable work is sent regularly. Students who do not submit work for an extended period of time will be removed from our roll.

Enrolment Criteria

Te Kura provides distance education for students living in New Zealand and overseas, from early childhood level through to Year 13.

You may be able to enrol with us if you meet certain eligibility criteria set by the Ministry of Education.

To check your eligibility, use the eligibility wizard on our website at www.tekura.school.nz/enrol-with-us/, or call us on 0800 65 99 88.

Index

Te Kupu Tohu

A		G	
Accounting	16	Gateway	54
Agriculture	18	General Mathematics	76
Agriculture and Horticulture	19, 68	General Music	83
Art	20	Geography	55
Art History	24	German	57
<hr/>		<hr/>	
B		H	
Beginners' Chinese	31	Health and Physical Education	60, 92
Beginners' French	52	Health Education	60
Beginners' German	57	History	62
Beginners' Japanese	70	History England 1558–1660	63
Beginners' Latin	72	History New Zealand in the 19th century	64
Beginners' Māori	113	Home Economics	65
Beginners' Spanish	103	Horticulture	67
Biology	25	Huarahi Trades Academy	115
Business Studies	27		
<hr/>		<hr/>	
C		I	
Calculus	79	Introducing Science	96
Chemistry	29	Introduction to Agriculture	18
Chinese	31	Introduction to Horticulture	67
Classical Studies	33		
Commerce Studies	35	J	
<hr/>		Japanese	
D		70	
Design	22	<hr/>	
Design and Visual Communication	37	K	
Digital Technology	40	Ka Mau Te Wehi	
<hr/>		113	
E		<hr/>	
Early Childhood	43	L	
Economics	44	Latin	
English	46	72	
Enterprise Studies	51	Legal Studies	
Everyday Science	97	73	
<hr/>		Life Skills	
F		75	
French	52	Literacy for Everyday Life	
<hr/>		50	
		<hr/>	
		M	
		Mathematics	
		76	
		Mathematics and Statistics	
		77	
		Media Studies	
		81	
		Music	
		83	

N	
Numeracy for Everyday Life	77

P	
Painting	21
Pathways Education	85
Performing Arts	91
Photography	23
Physical Education	92
Physics	94
Pregnancy and Childcare	90
Primary Spanish	103
Printmaking	21

R	
Religious Studies	33

S	
Science	96
Sculpture	22
Social Studies	102
Spanish	103
Special Education Art	106
Special Education English	106
Special Education Health and PE	106
Special Education Life Skills	106
Special Education Maths	106
Special Education Science	106
Special Education Social Studies	107
Special Education Technology	107
STAR	54
Statistics	79
Subjects at a glance	12
Supported Learning Standards	107

T	
Te Ara Hou Integrated Programme	109
Technology	110, 111
Te Reo Māori	113
Tertiary Link	115

V	
Visual Arts	20

Y	
Years 1 to 6	116